



Negative Ion Studies in an IEC Fusion Device

By: Eric C. Alderson, J.F. Santarius,
G.A. Emmert, G.L. Kulcinski
December 2011

13th US-Japan workshop on
Inertial Electrostatic Confinement
Fusion
Sydney, Australia

Outline



- Historical development
- Review of negative ion physics in the IEC device
- Negative ion modeling in the VICTER code
- Negative ion spatial measurements
- Future work

Historical Development



- Negative ions first measured in the IEC on October 3, 2008 via the *Magnetic Deflection Energy Analyzer (MDEA)* by **D. Boris**.
 - Negative ion current energy spectra at the wall of the IEC as a function of cathode voltage, current, and gas pressure characterized.
 - Negative ion currents confirmed by “Faraday trap”.
- 11th US-Japan IEC Workshop on October 13, 2009
 - First reporting of significant negative ion currents in the IEC by D. Boris.
 - Plans for mobile Faraday cup for spatial measurement of negative ions made.
 - Cross sections assembled for modeling of negative ion creation and propagation
- 12th US-Japan IEC Workshop October 21, 2010
 - Initial modeling of negative ion propagation.
 - Faraday cup constructed and installed in the IEC for radial measurements of negative ions.
 - Radial profiles of negative ions on jet and off jet measured at numerous cathode voltages, currents, and pressures.

Historical Development



- Negative ions first measured in the IEC on October 3, 2008 via the *Magnetic Deflection Energy Analyzer (MDEA)* by **D. Boris**.
 - Negative ion current energy spectra at the wall of the IEC as a function of cathode voltage, current, and gas pressure characterized.
 - Negative ion currents confirmed by “Faraday trap”.
- 11th US-Japan IEC Workshop on October 13, 2009
 - First reporting of significant negative ion currents in the IEC by D. Boris.
 - Plans for mobile Faraday cup for spatial measurement of negative ions made.
 - Cross sections assembled for modeling of negative ion creation and propagation
- 12th US-Japan IEC Workshop October 21, 2010
 - Initial modeling of negative ion propagation.
 - Faraday cup constructed and installed in the IEC for radial measurements of negative ions.
 - Radial profiles of negative ions on jet and off jet measured at numerous cathode voltages, currents, and pressures.

Historical Development



- Negative ions first measured in the IEC on October 3, 2008 via the *Magnetic Deflection Energy Analyzer (MDEA)* by **D. Boris**.
 - Negative ion current energy spectra at the wall of the IEC as a function of cathode voltage, current, and gas pressure characterized.
 - Negative ion currents confirmed by “Faraday trap”.
- 11th US-Japan IEC Workshop on October 13, 2009
 - First reporting of significant negative ion currents in the IEC by D. Boris.
 - Plans for mobile Faraday cup for spatial measurement of negative ions made.
 - Cross sections assembled for modeling of negative ion creation and propagation
- 12th US-Japan IEC Workshop October 21, 2010
 - Initial modeling of negative ion propagation.
 - Faraday cup constructed and installed in the IEC for radial measurements of negative ions.
 - Radial profiles of negative ions on jet and off jet measured at numerous cathode voltages, currents, and pressures.

Negative ions are formed in the IEC by charge exchange or electron attachment

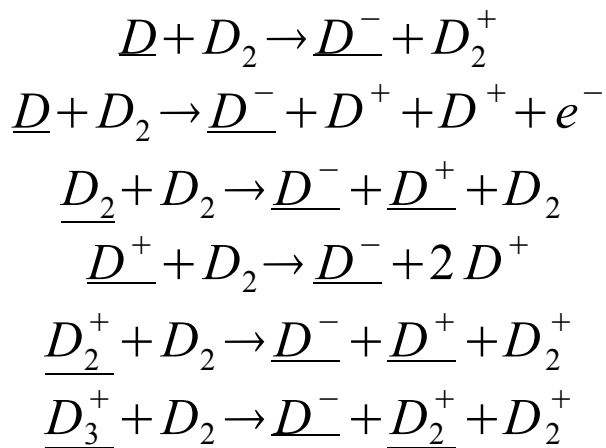
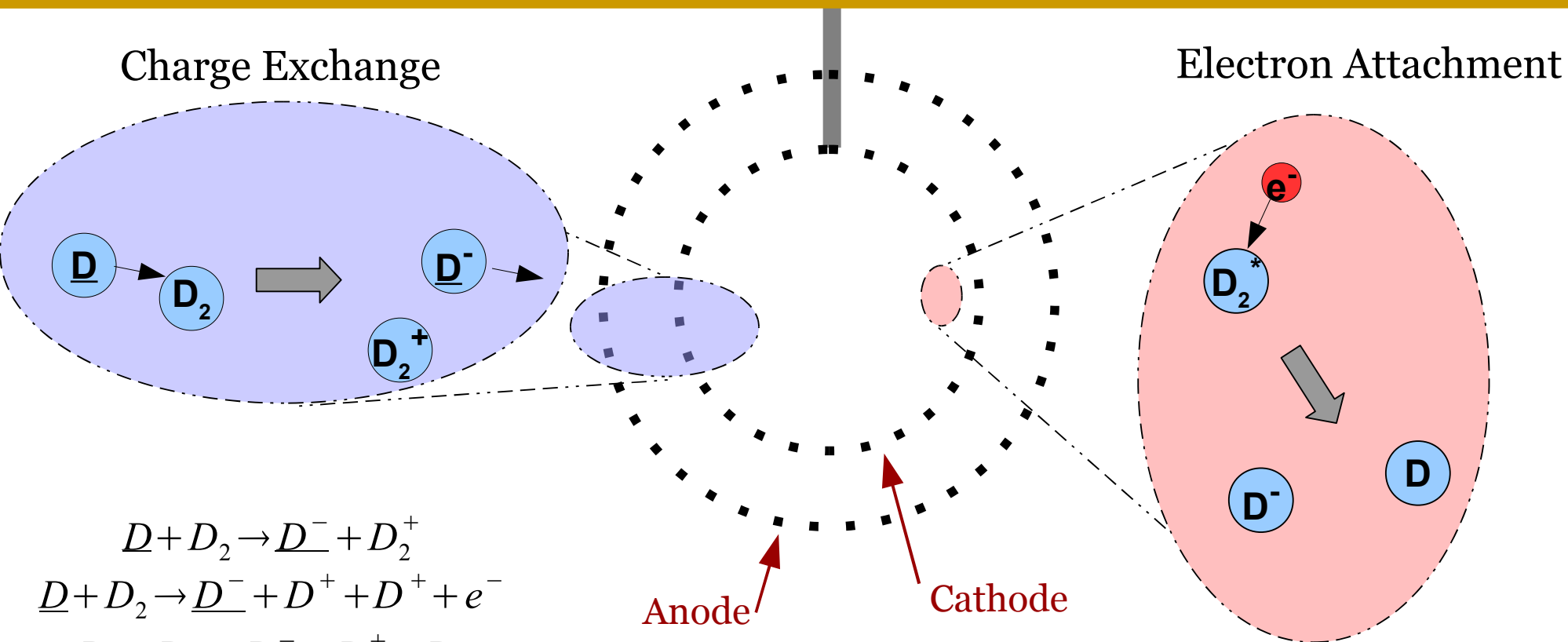

Underline denotes fast species

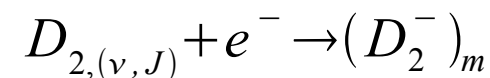
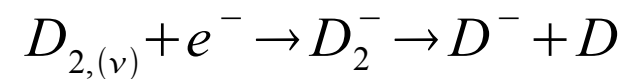

Negative ion current creation and propagation added to VICTER code.

Main code calculates ion and fast neutral energy spectra at all radii.
Negative ion subroutine calculates creation of negative ions from these spectra.

Propagation is considered from sources in three categories:

(1) Currents that are born inward and can overcome the potential well, passing through the center of the device.

(2) Currents that are born inward and cannot overcome the potential well, being reflected before reaching the cathode.

(3) Currents that are born outward.

Fast neutral currents from negative ions calculated as negative ions are attenuated.

Fusion from negative ions and daughter fast neutrals calculated.

Negative ion subroutine treats negative ions as a perturbation on the positive-ion and neutral currents.

The VICTER code is not equipped to calculate currents from electron attachment.

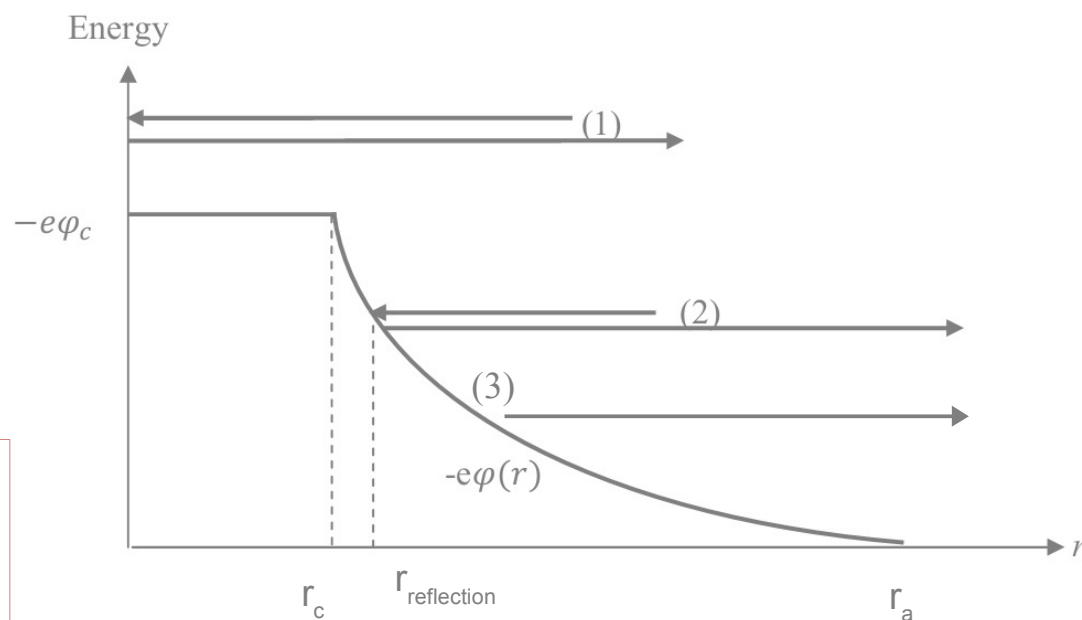

Negative ion current creation and propagation added to VICTER code.

Main code calculates ion and fast neutral energy spectra at all radii.
Negative ion subroutine calculates creation of negative ions from these spectra.

Propagation is considered from sources in three categories:

- (1) Currents that are born inward and can overcome the potential well, passing through the center of the device.
- (2) Currents that are born inward and cannot overcome the potential well, being reflected before reaching the cathode.
- (3) Currents that are born outward.

Fast neutral currents from negative ions calculated as negative ions are attenuated.

Fusion from negative ions and daughter fast neutrals calculated.

Negative ion subroutine treats negative ions as a perturbation on the positive-ion and neutral currents.

The VICTER code is not equipped to calculate currents from electron attachment.

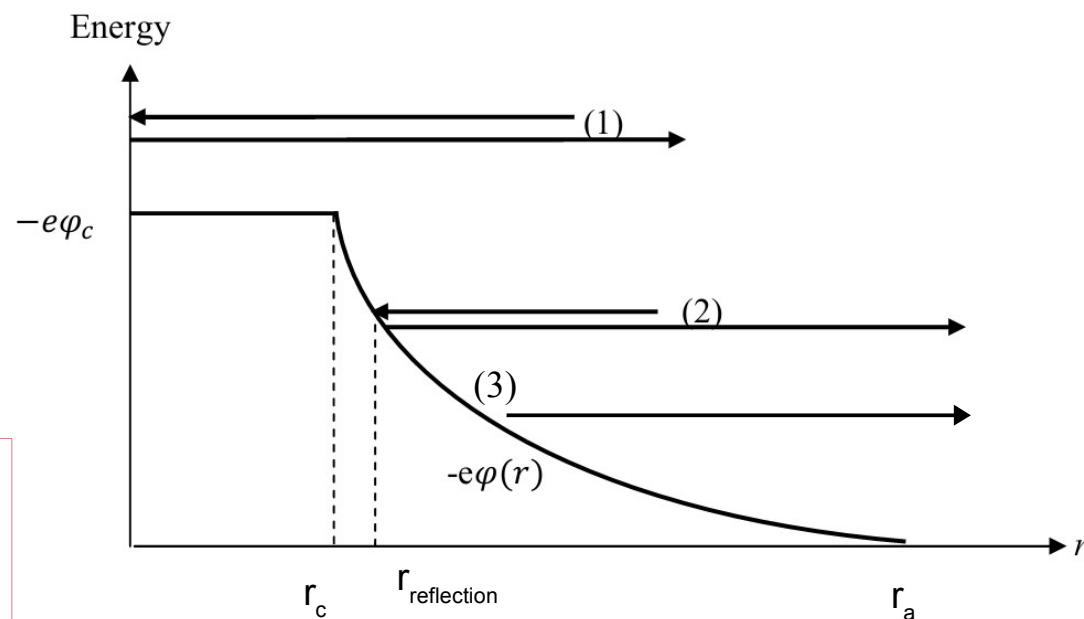

Negative ion current creation and propagation added to VICTER code.

Main code calculates ion and fast neutral energy spectra at all radii.
Negative ion subroutine calculates creation of negative ions from these spectra.

Propagation is considered from sources in three categories:

- (1) Currents that are born inward and can overcome the potential well, passing through the center of the device.
- (2) Currents that are born inward and cannot overcome the potential well, being reflected before reaching the cathode.
- (3) Currents that are born outward.

Fast neutral currents from negative ions calculated as negative ions are attenuated.

Fusion from negative ions and daughter fast neutrals calculated.

Negative ion subroutine treats negative ions as a perturbation on the positive-ion and neutral currents.

The VICTER code is not equipped to calculate currents from electron attachment.

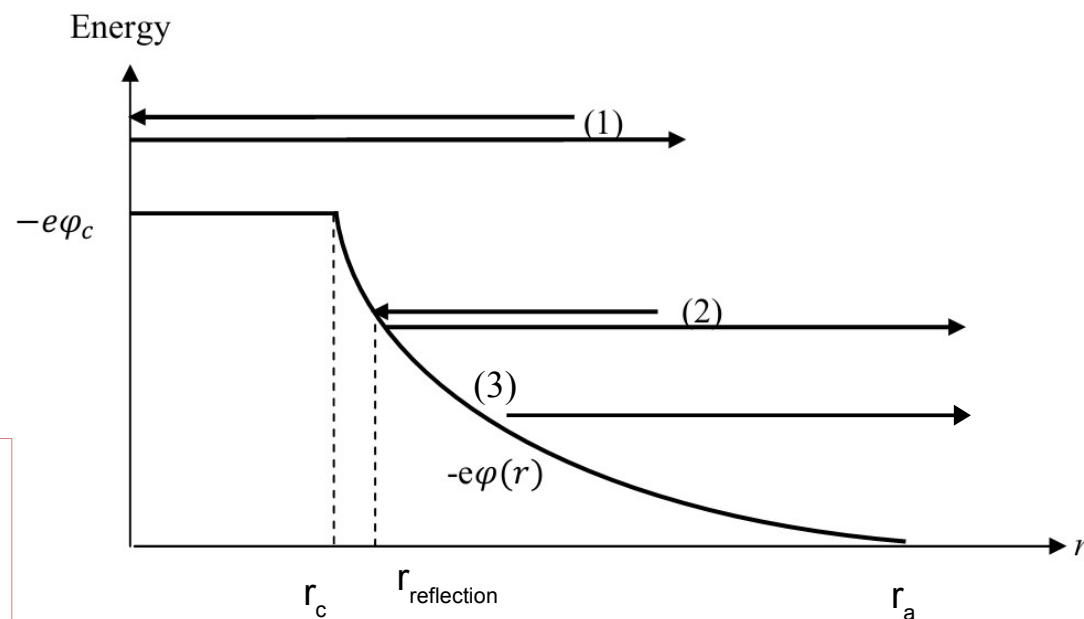

Negative ion current creation and propagation added to VICTER code.

Main code calculates ion and fast neutral energy spectra at all radii.
Negative ion subroutine calculates creation of negative ions from these spectra.

Propagation is considered from sources in three categories:

- (1) Currents that are born inward and can overcome the potential well, passing through the center of the device.
- (2) Currents that are born inward and cannot overcome the potential well, being reflected before reaching the cathode.
- (3) Currents that are born outward.

Fast neutral currents from negative ions calculated as negative ions are attenuated.

Fusion from negative ions and daughter fast neutrals calculated.

Negative ion subroutine treats negative ions as a perturbation on the positive-ion and neutral currents.

The VICTER code is not equipped to calculate currents from electron attachment.

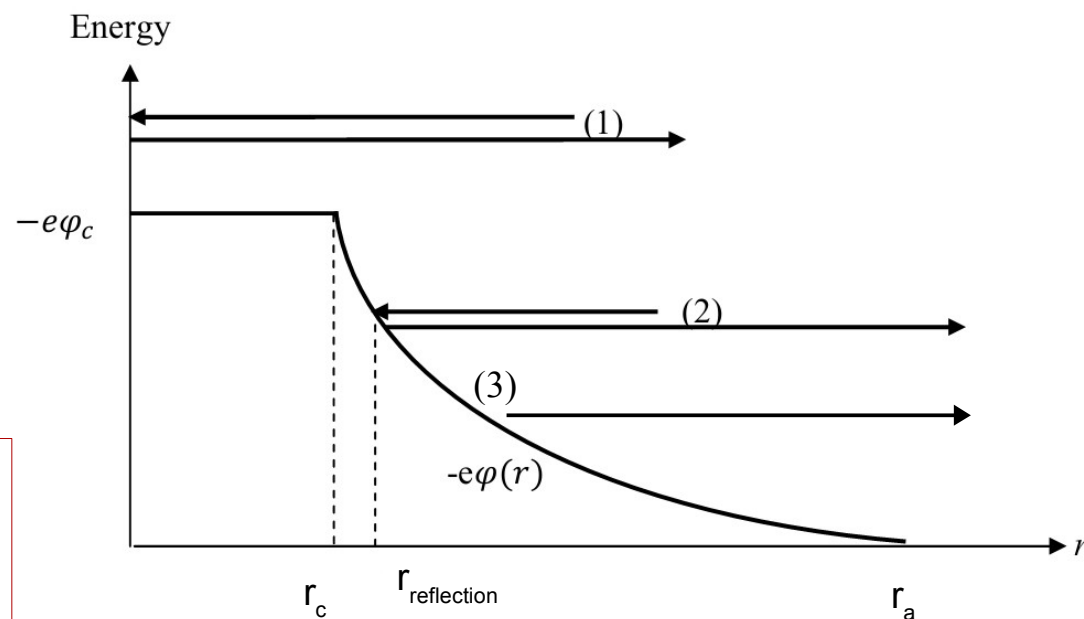

VICTER code output shows negative ion energy spectra evolution with radius.

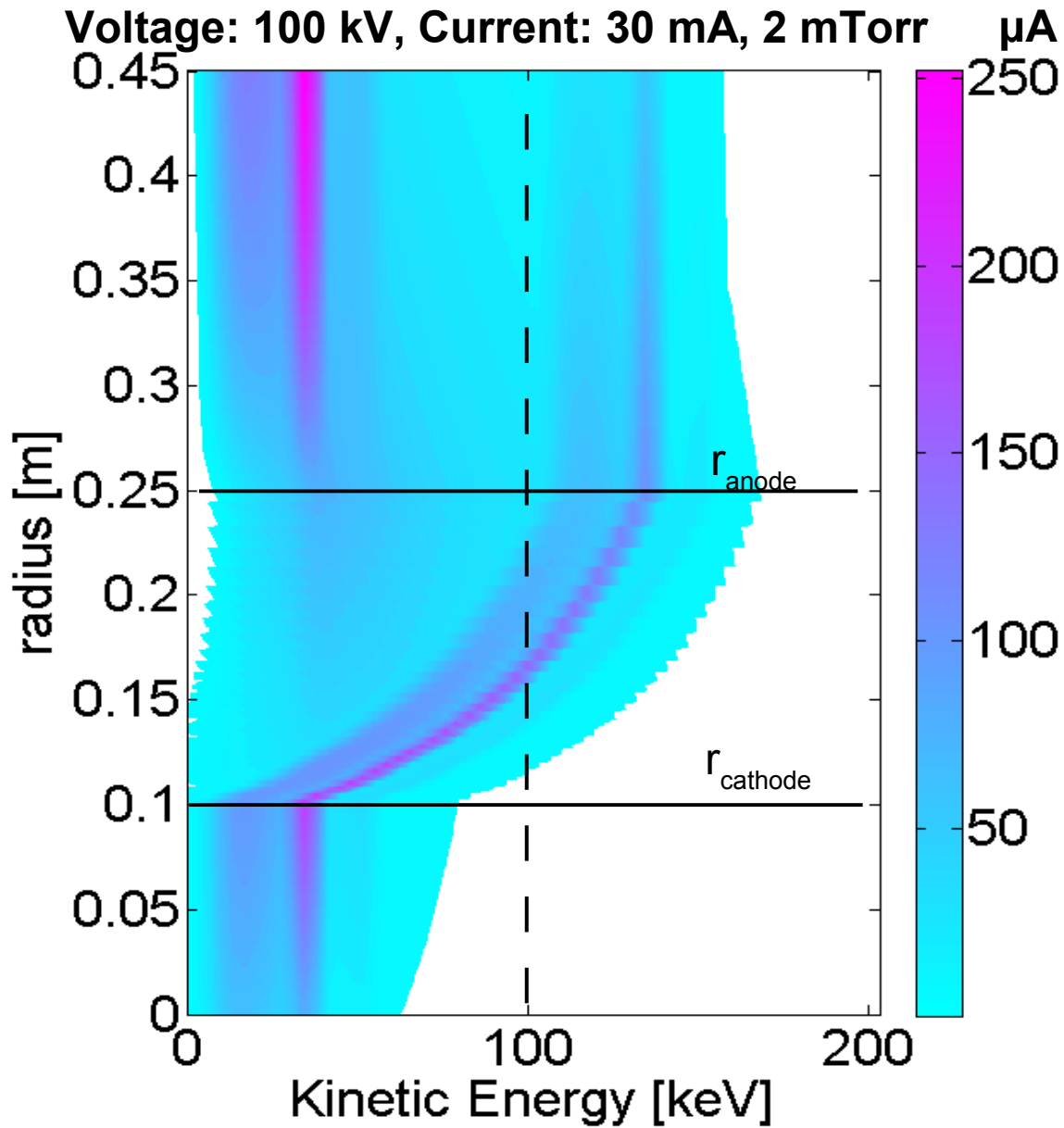

VICTER code output shows negative ion energy spectra evolution with radius.

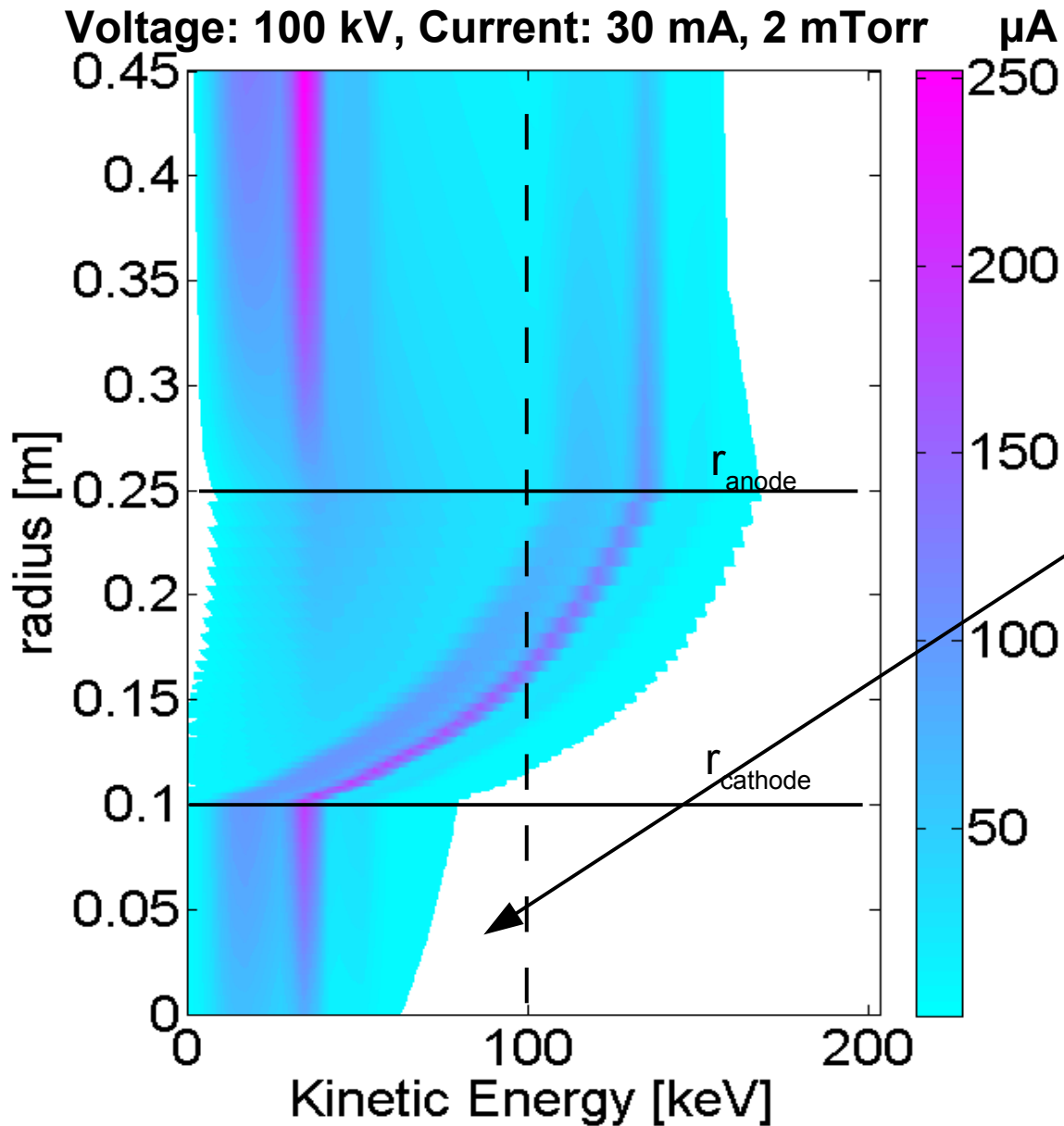

Negative ions born in the cathode undergo no acceleration

VICTER code output shows negative ion energy spectra evolution with radius.

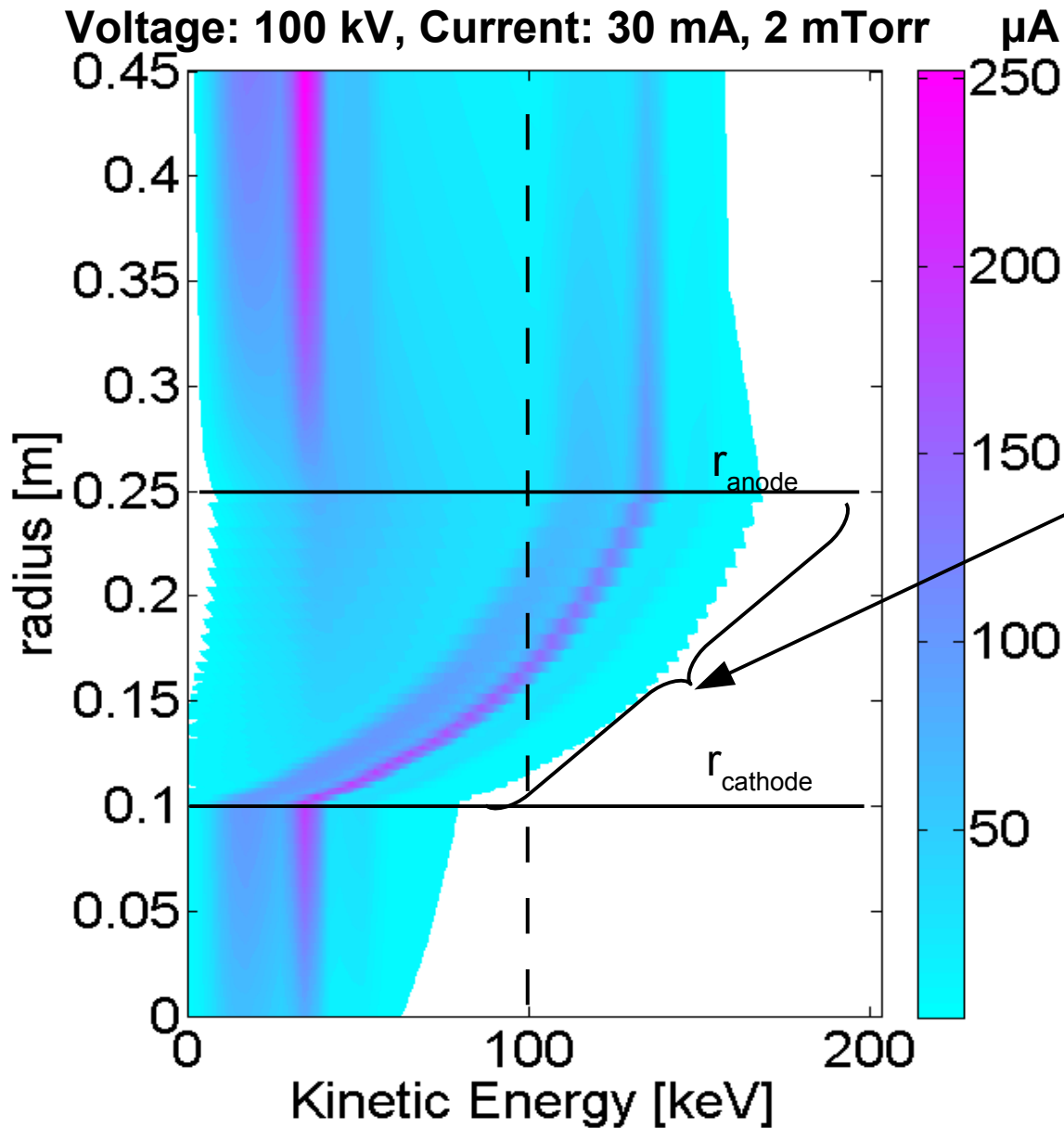

Negative ions in the inter-grid region gain kinetic energy from to the cathode potential as they travel outwards, some current gaining more energy than the cathode potential energy due to a tandem accelerator like process.

VICTER code output shows negative ion energy spectra evolution with radius.

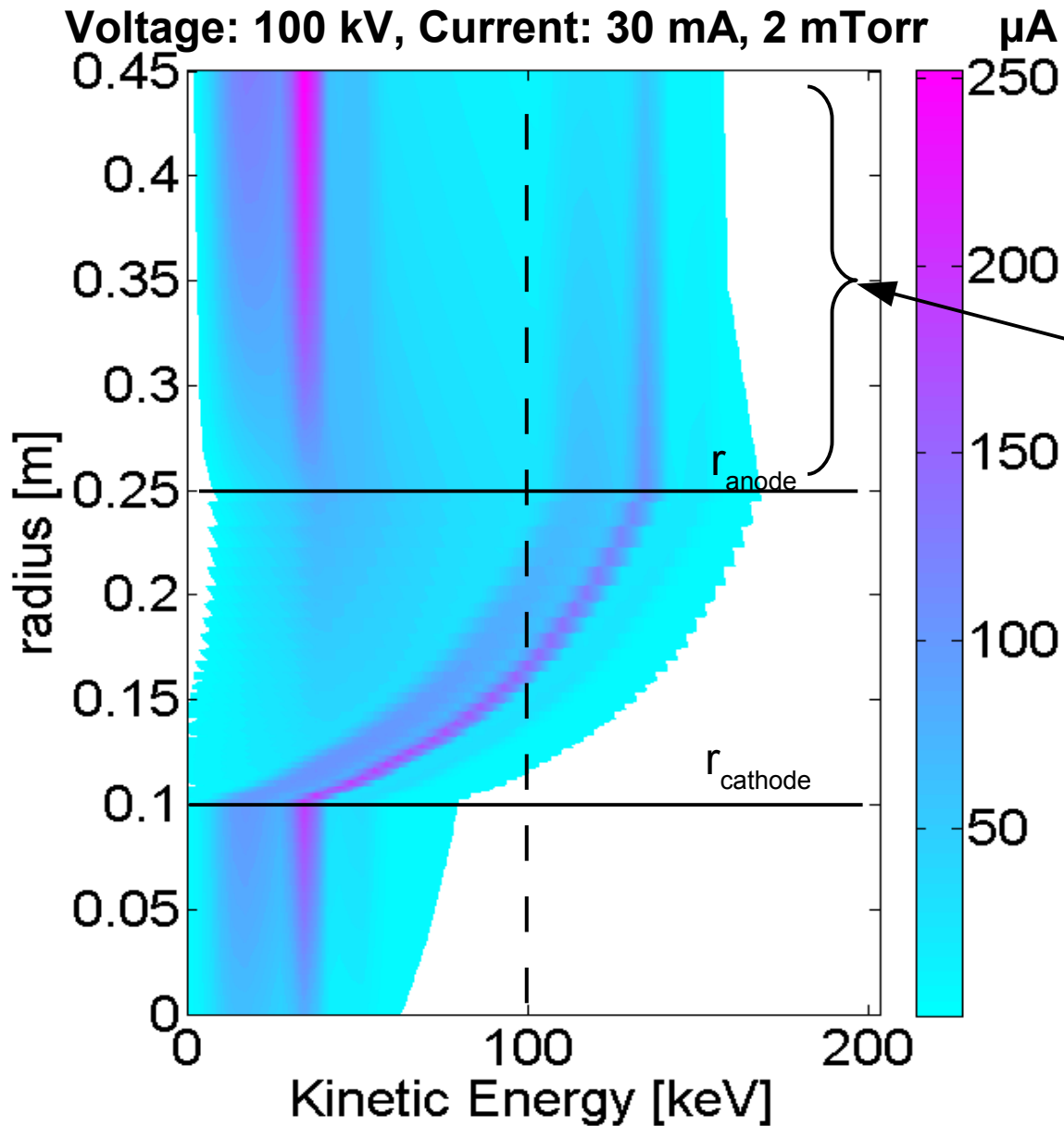

Outside the anode the negative ions undergo no acceleration. Negative ion population with more energy than cathode potential attenuate as they travel.

VICTER code output shows negative ion energy spectra evolution with radius.

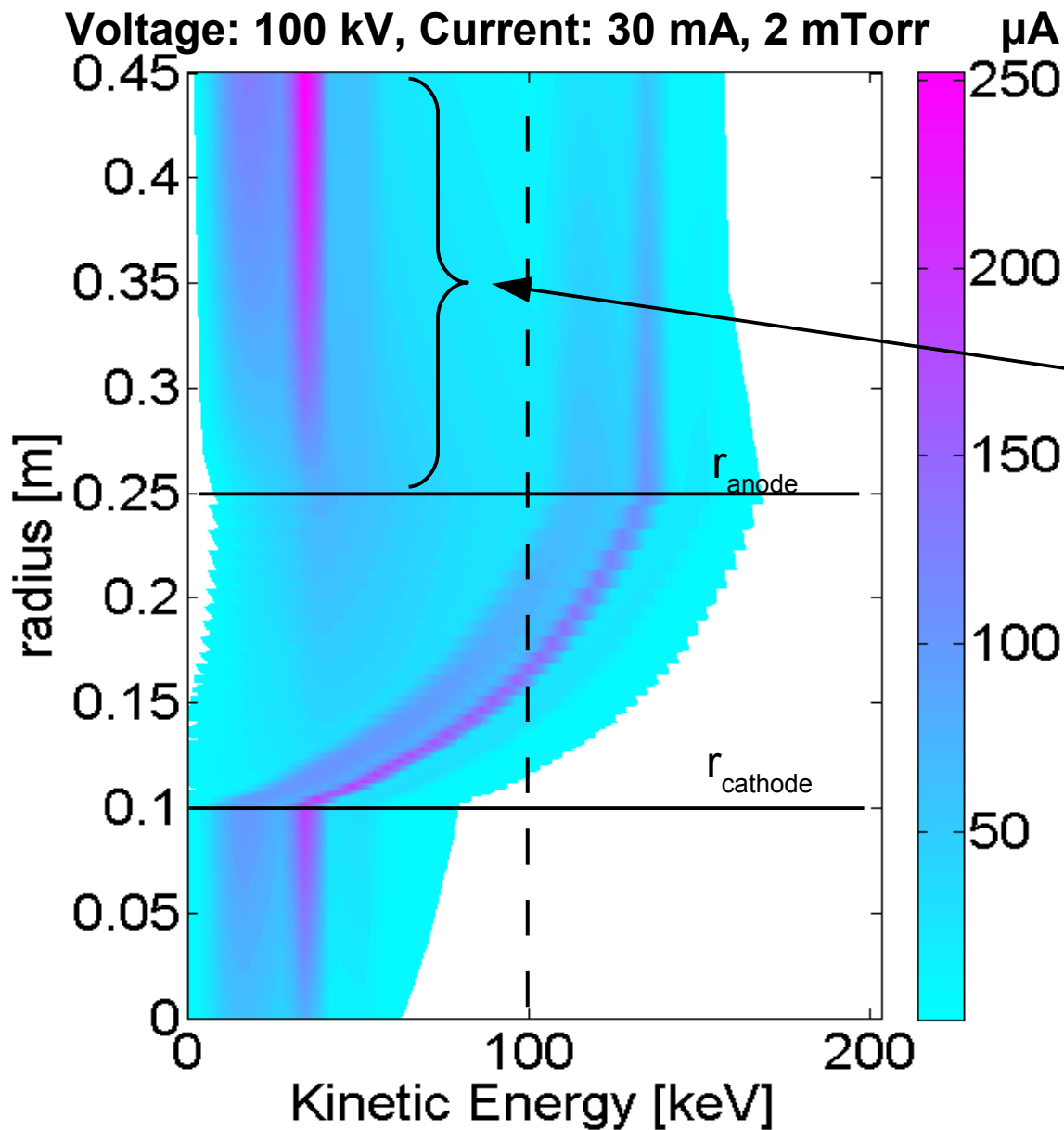

Negative ion current seems to be born from fast neutrals faster than attenuation due to stripping collisions

VICTER code results show similar radial trends to Faraday cup radial measurements.

Voltage: 30 kV, Current: 15 mA, 2 mTorr

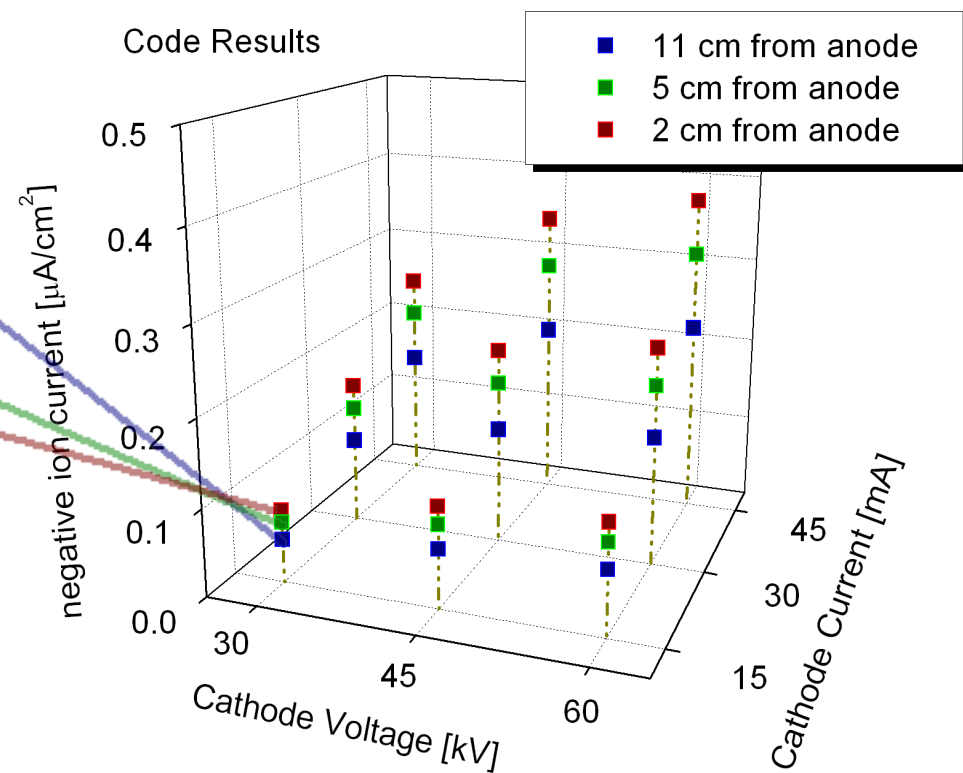
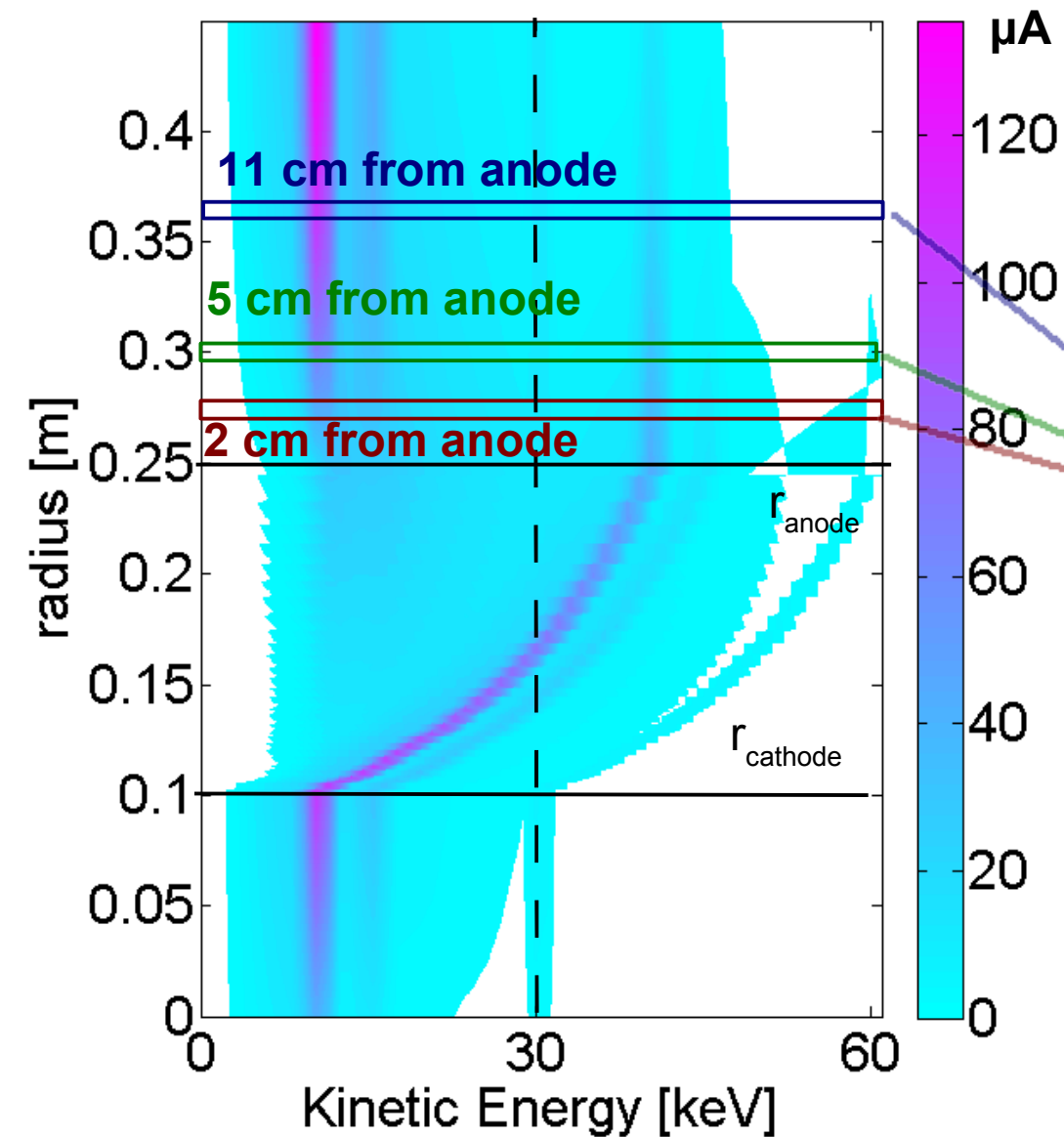

VICTER code results show similar radial trends to Faraday cup radial measurements.

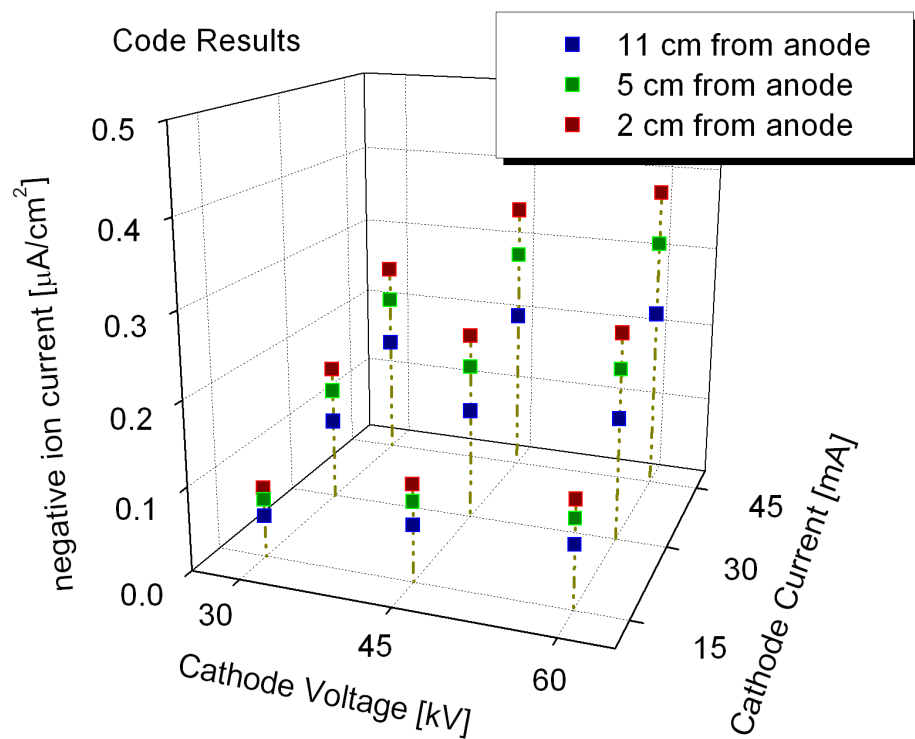

VICTER code results

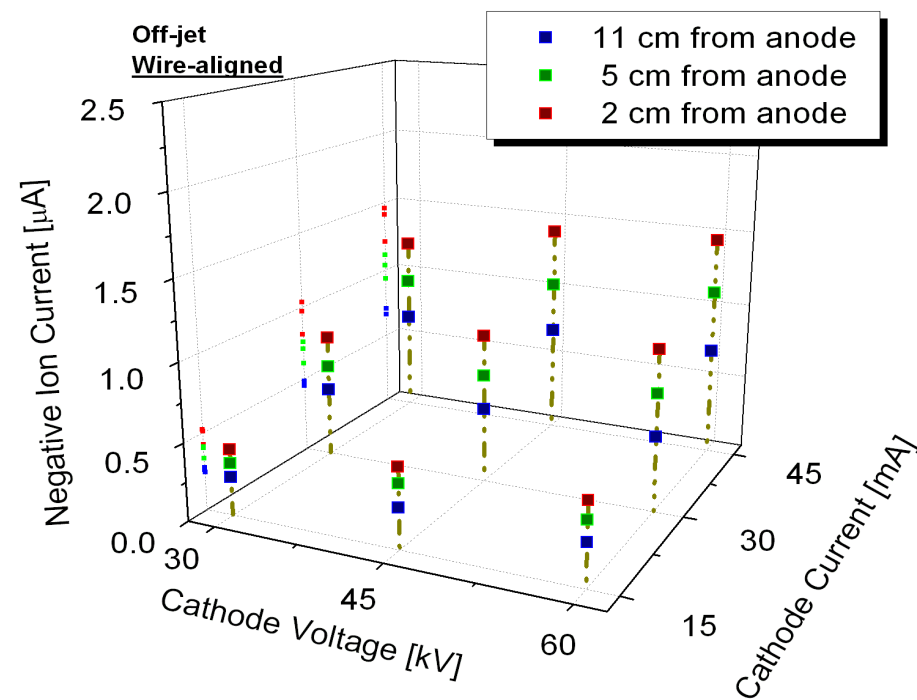

Faraday cup results – 1 cm^2 aperture

VICTER code results show similarities to Magnetic Deflection Energy Analyzer results.

Voltage: 100 kV, Current: 30 mA, 2 mTorr

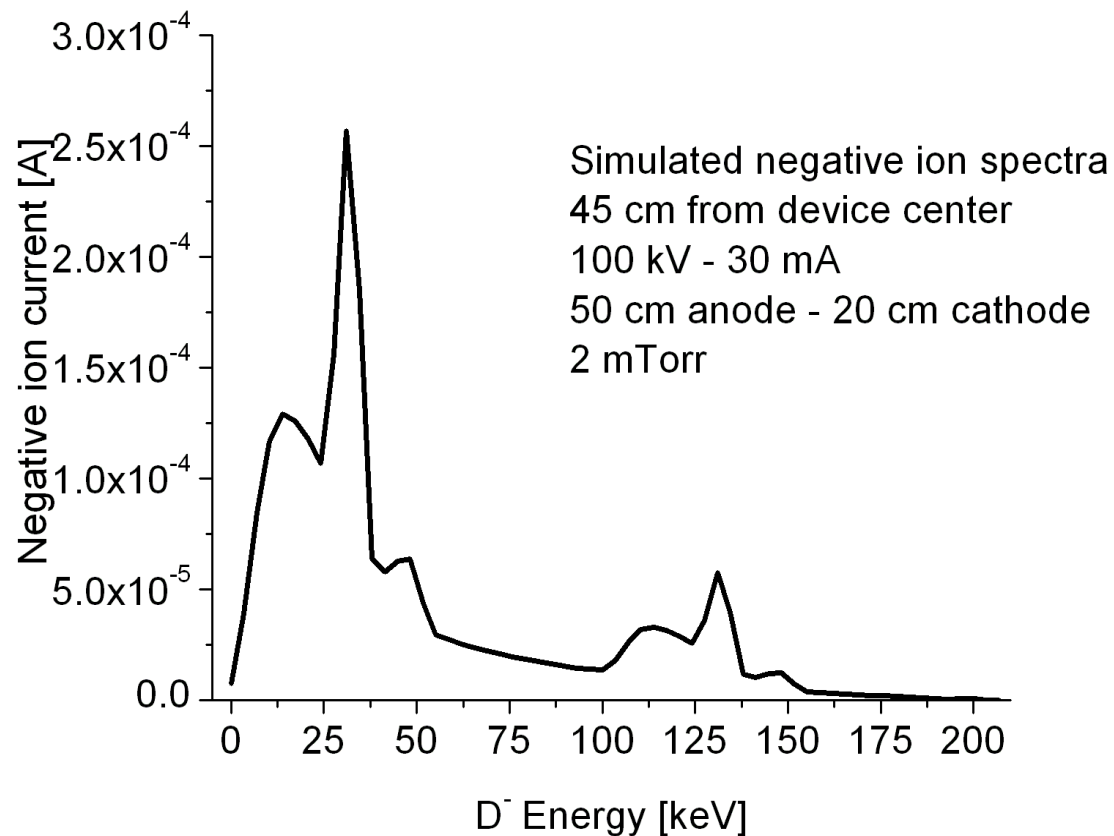
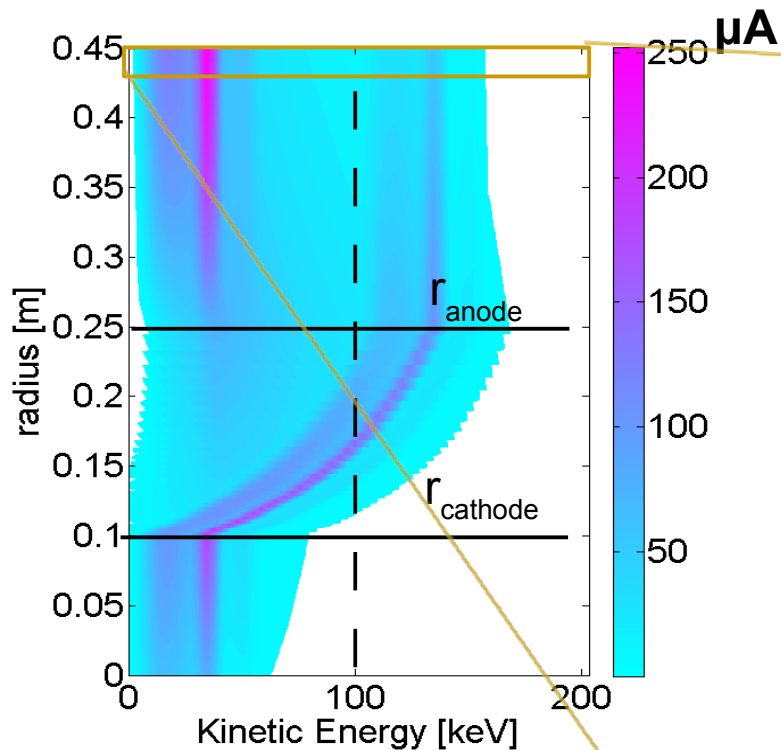

VICTER code results show similarities to Magnetic Deflection Energy Analyzer results.

Voltage: 100 kV, Current: 30 mA, 2 mTorr

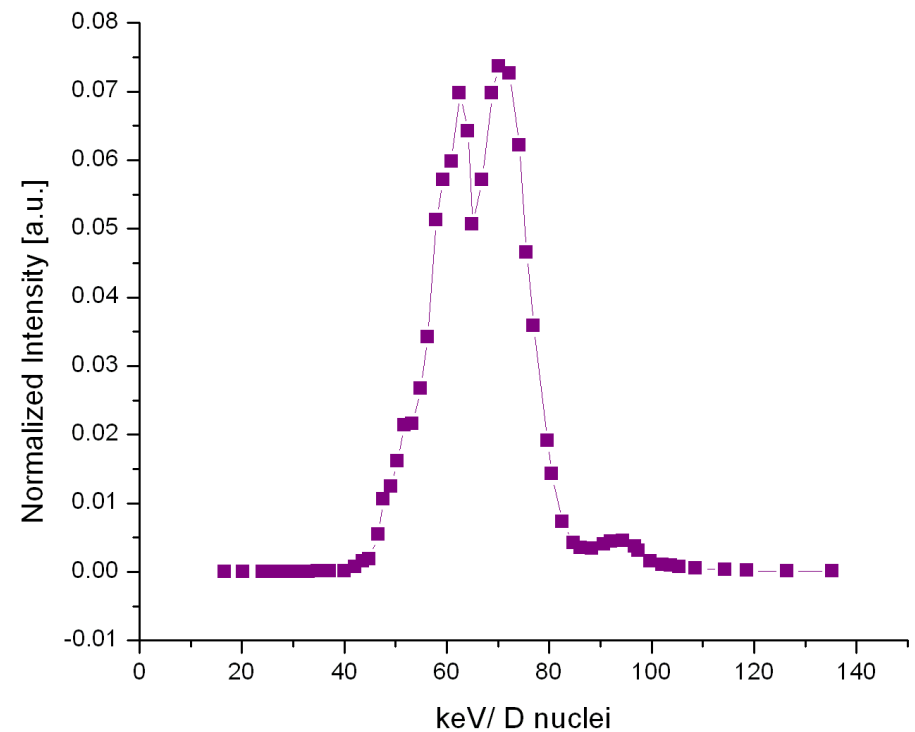
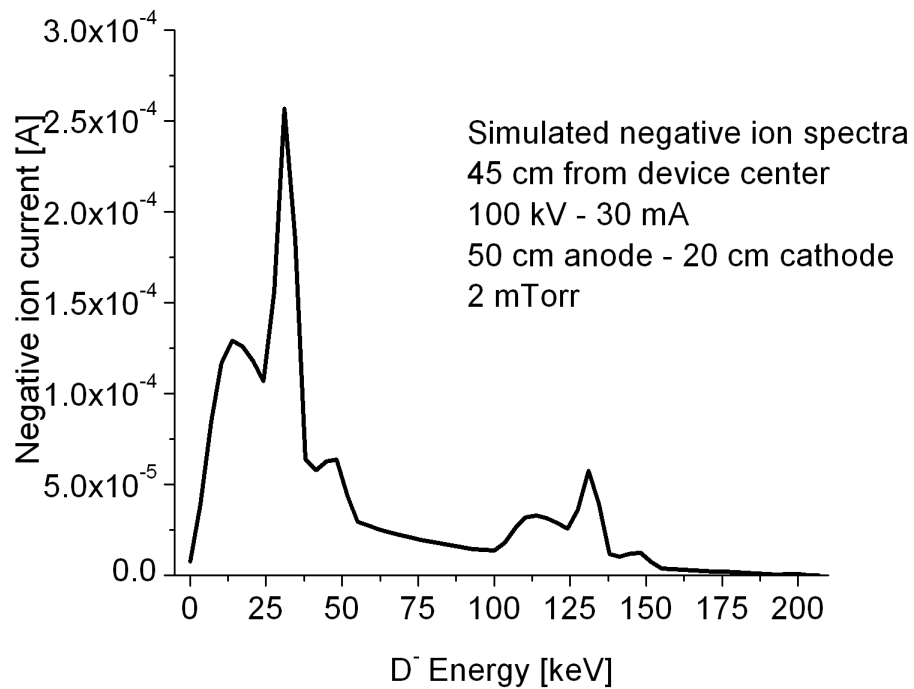

Theory Result
VICTER code

Experimental Result
Magnetic Deflection Energy
Analyzer

The VICTER code can be a tool to examine the sources of negative ion energy spectra structure.

Voltage: 100 kV, Current: 30 mA, 2 mTorr

Negative ion spectra from each parent species

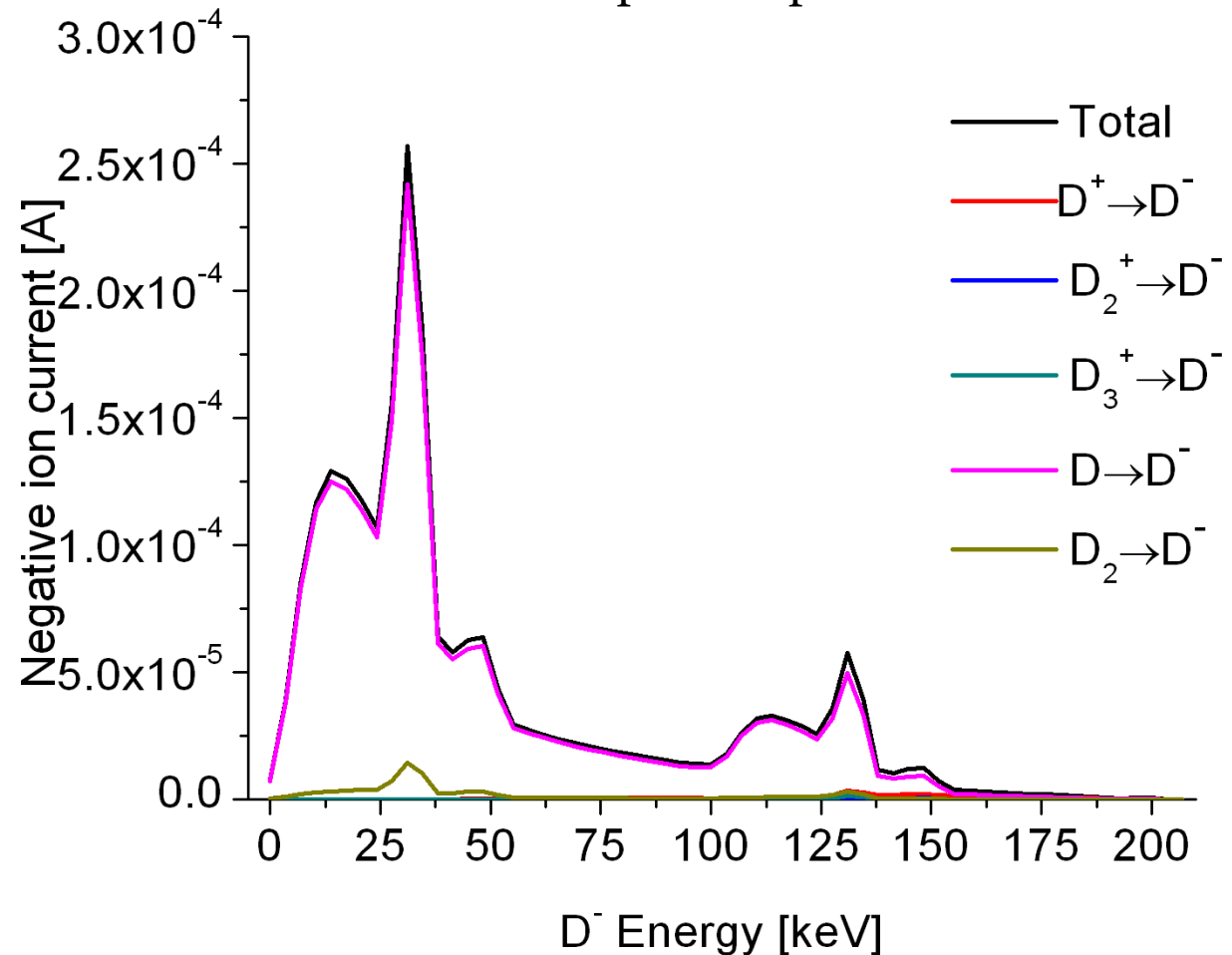
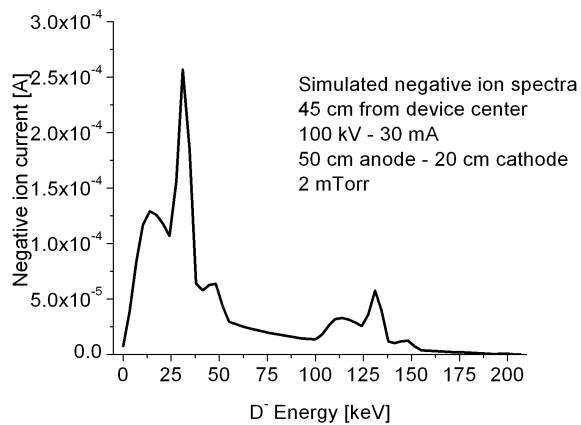

The VICTER code can be a tool to examine the sources of negative ion energy spectra structure.

Voltage: 100 kV, Current: 30 mA, 2 mTorr

Negative ion spectra from each parent species

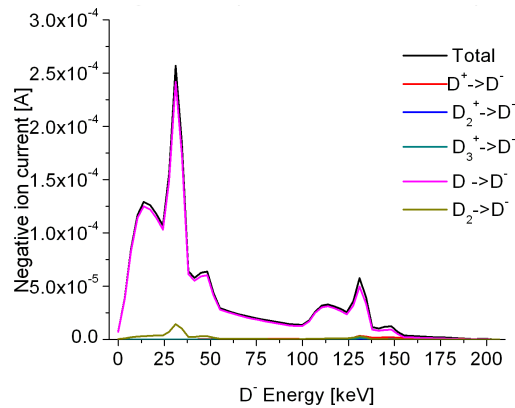

D^- Energy [keV]

Negative ion spectra from each grandparent species

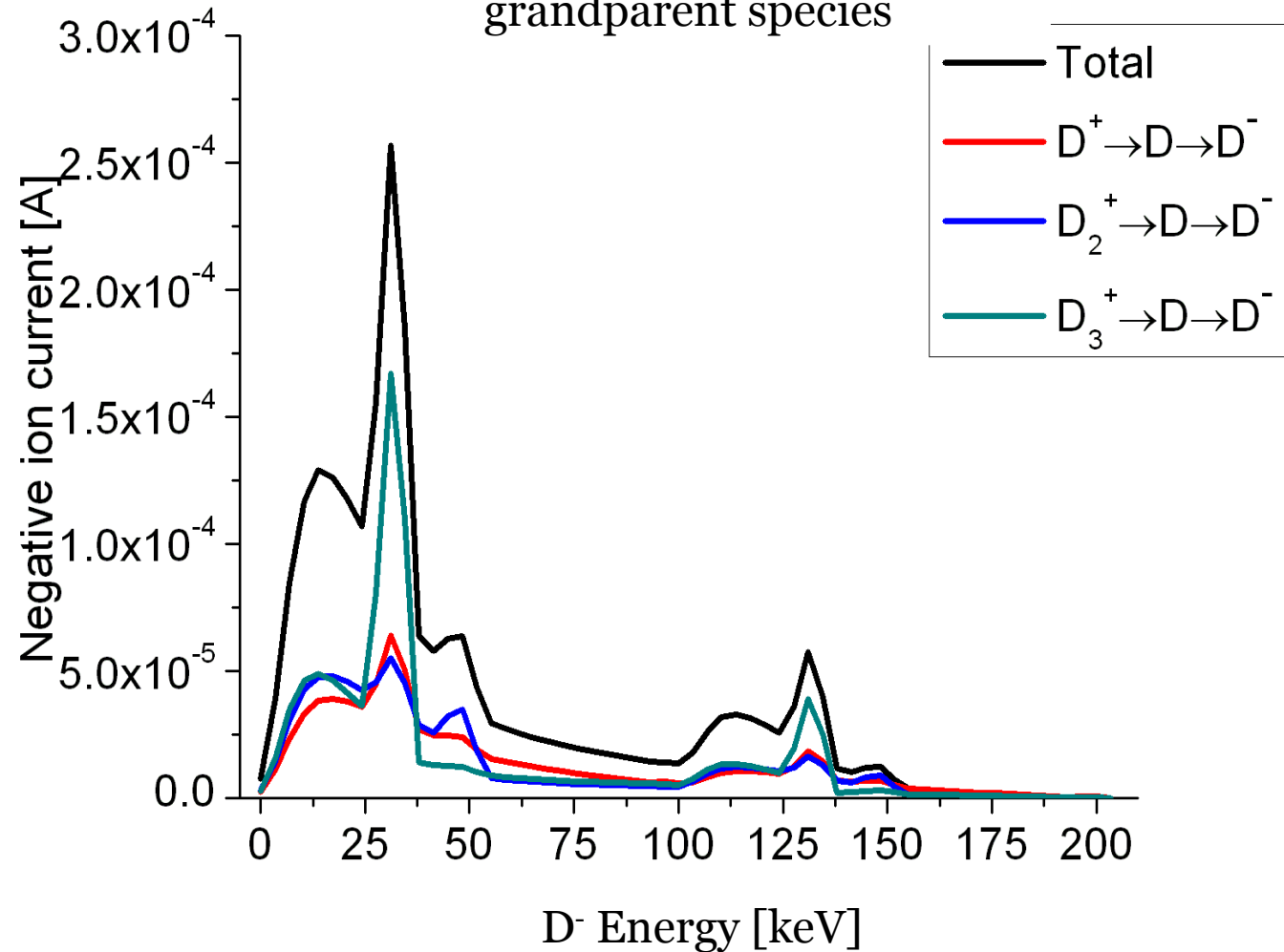

VICTER code predicts negatives ions are a relevant source of fusion.

Amount of fusion from negative ions is strongly dependent on background pressure. According to the VICTER code:

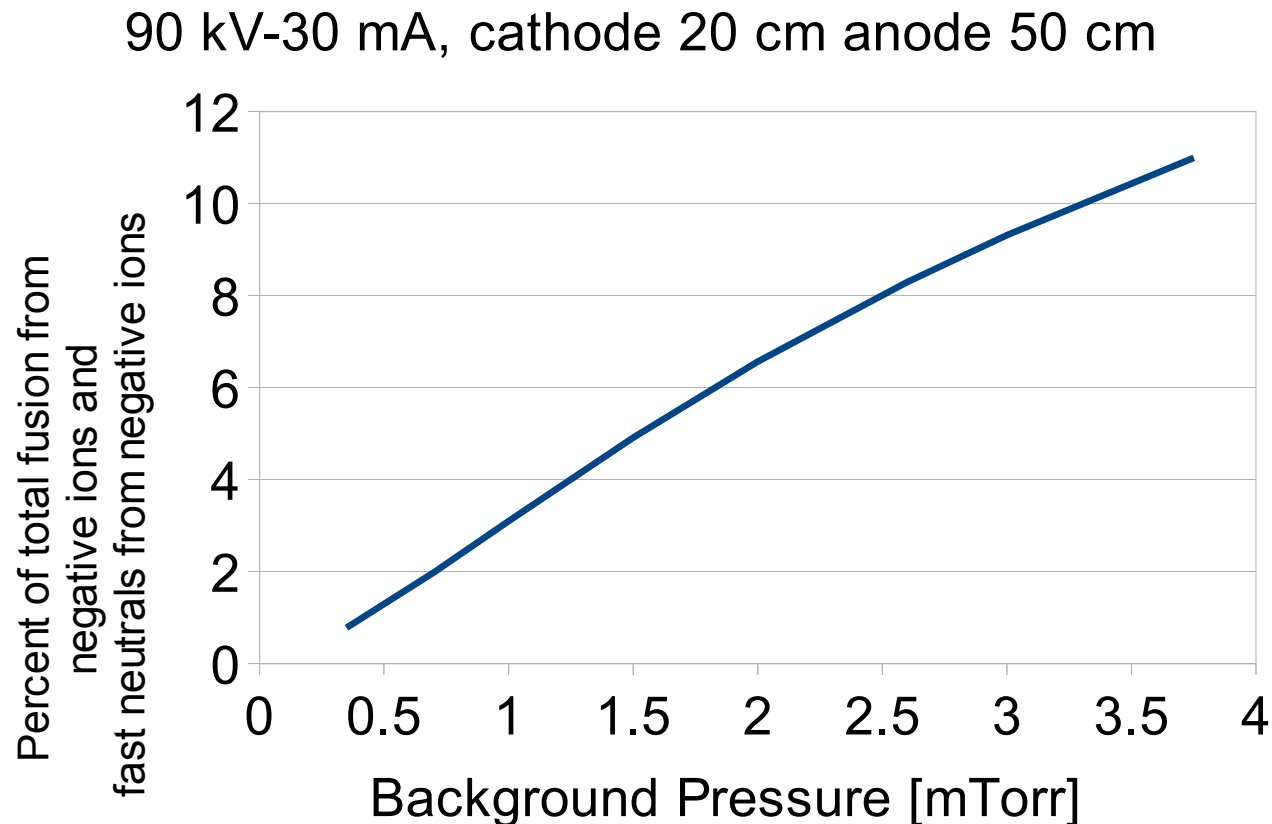

The Faraday cup has measured spatial negative ion current profiles in the IEC.

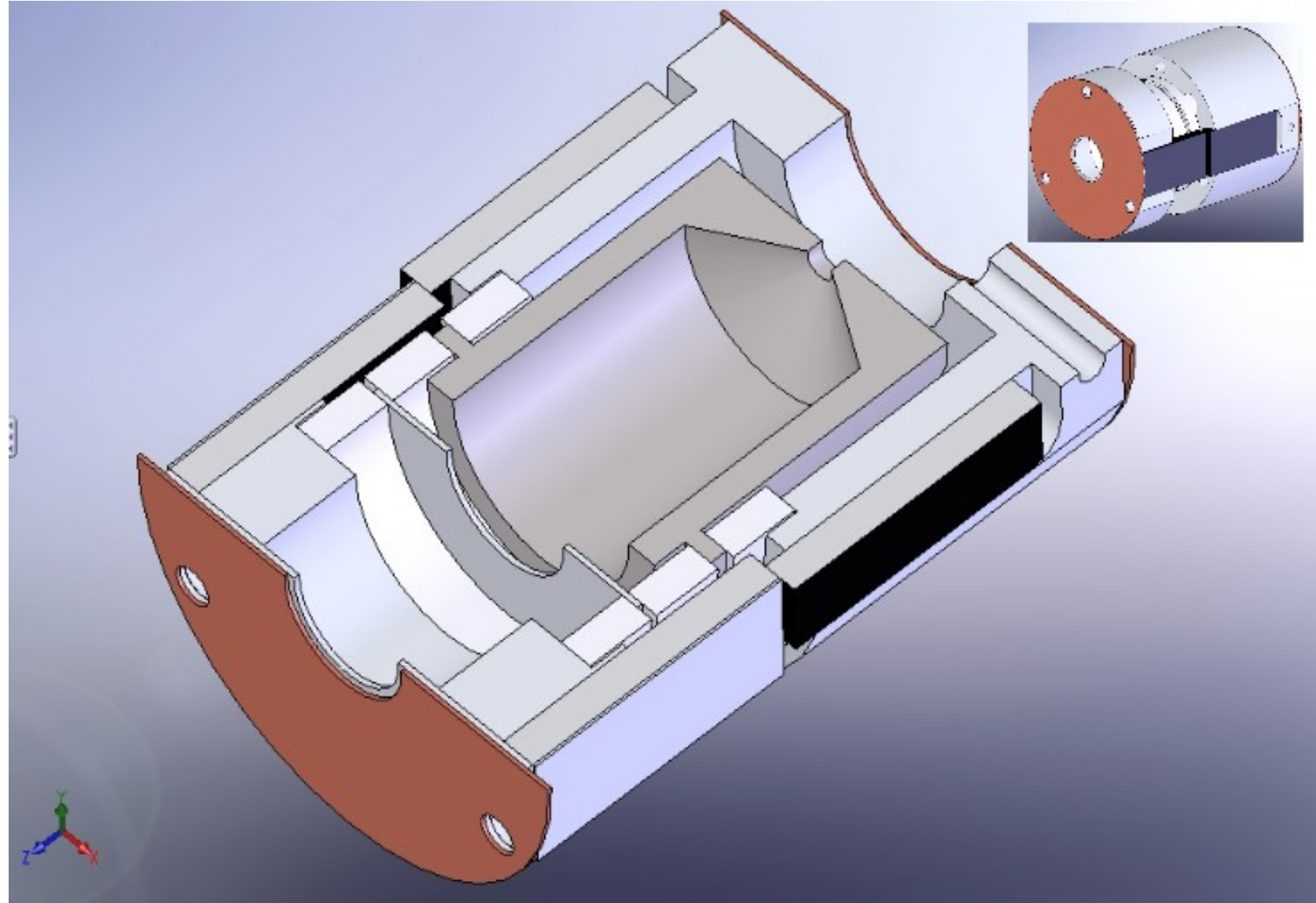

The Faraday cup has measured spatial negative ion current profiles in the IEC.

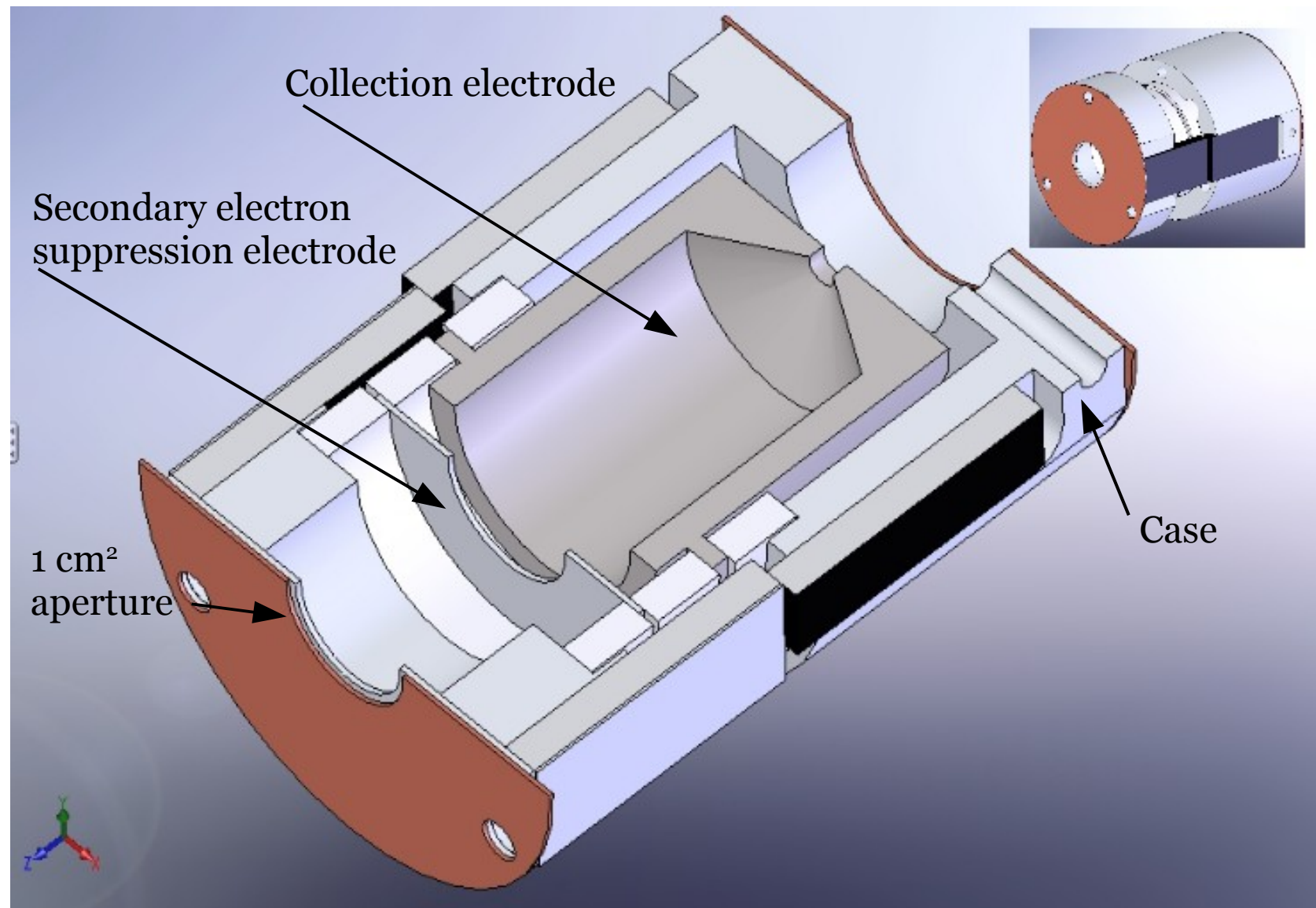

The Faraday cup has measured spatial negative ion current profiles in the IEC.

Magnets and field

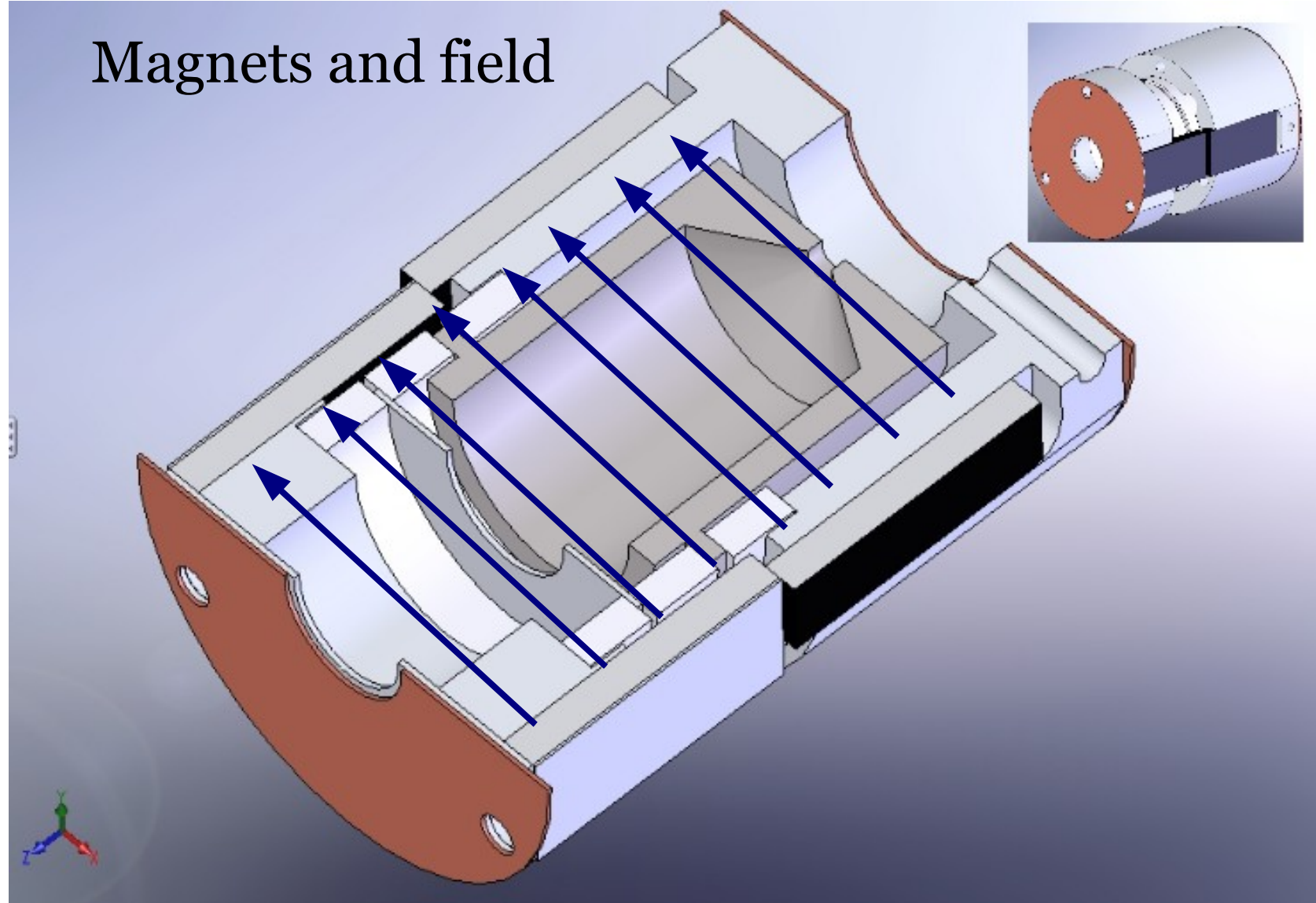

The Faraday cup has measured spatial negative ion current profiles in the IEC.

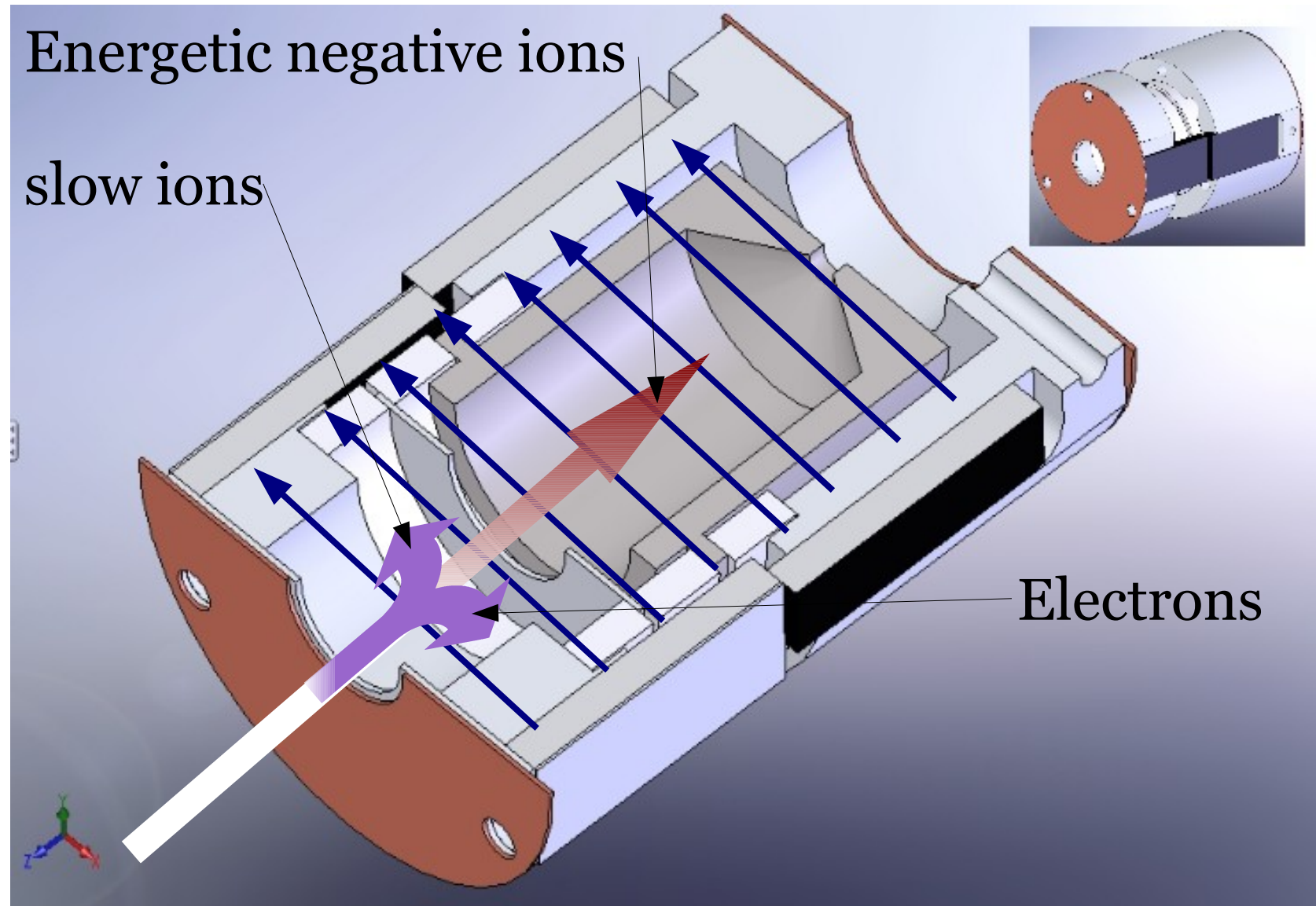

The Faraday cup has measured spatial negative ion current profiles in the IEC.

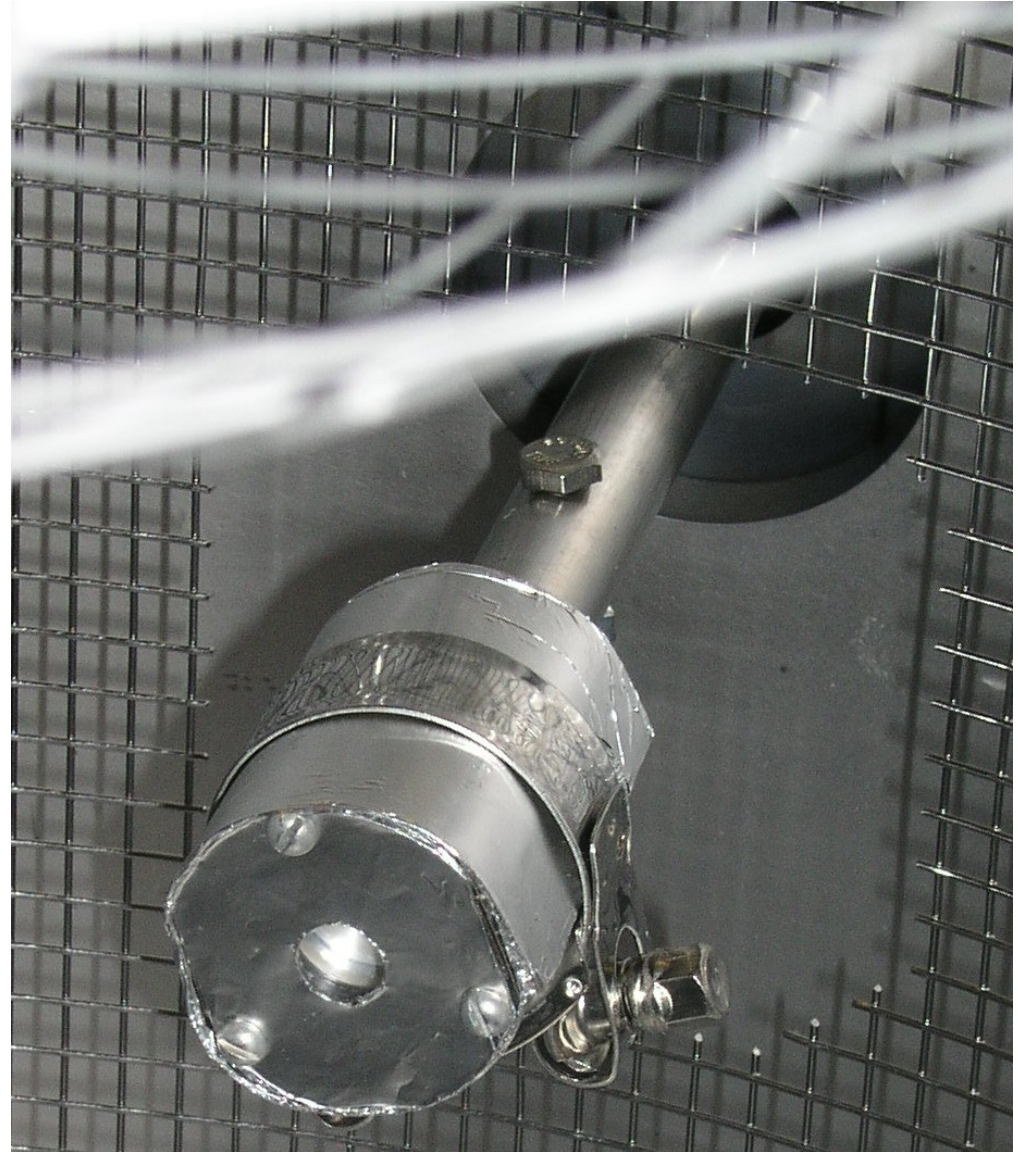
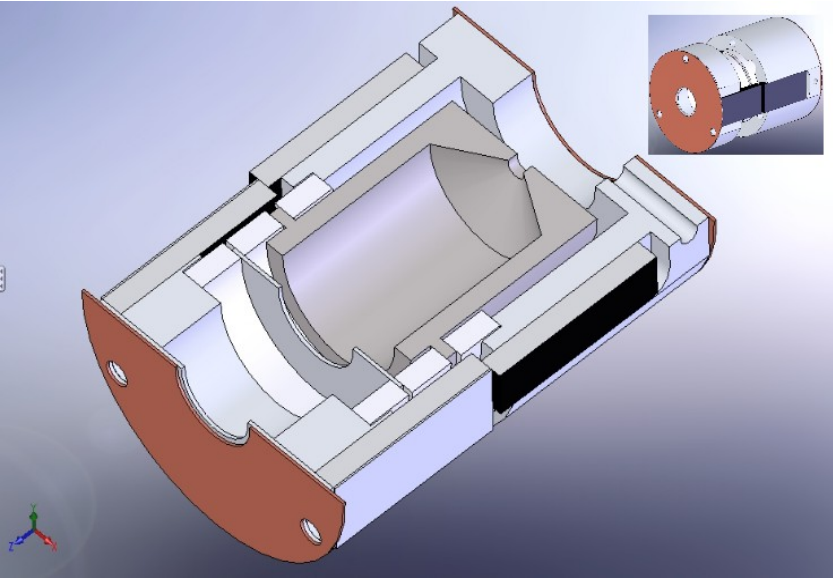

The Faraday cup has measured spatial negative ion current profiles in the IEC.

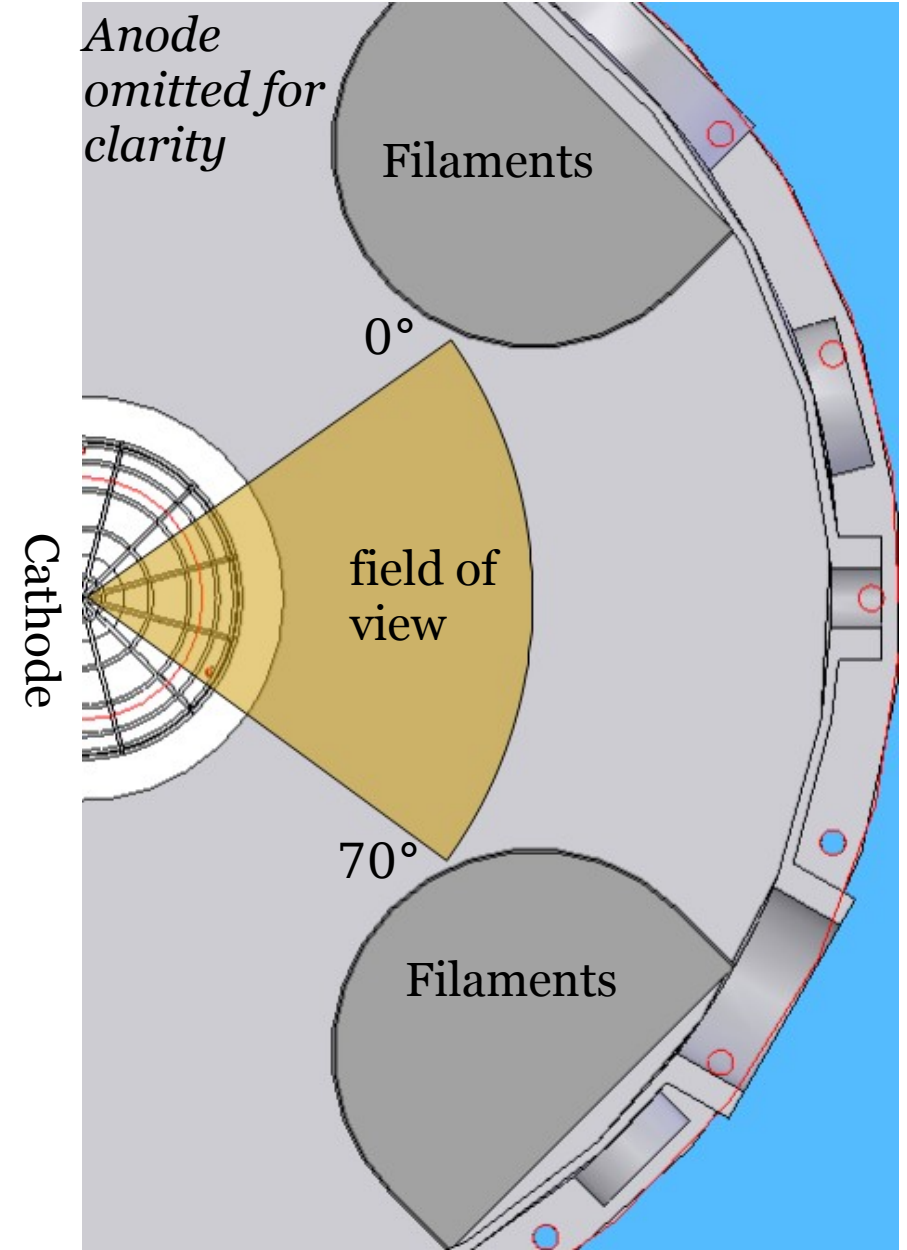
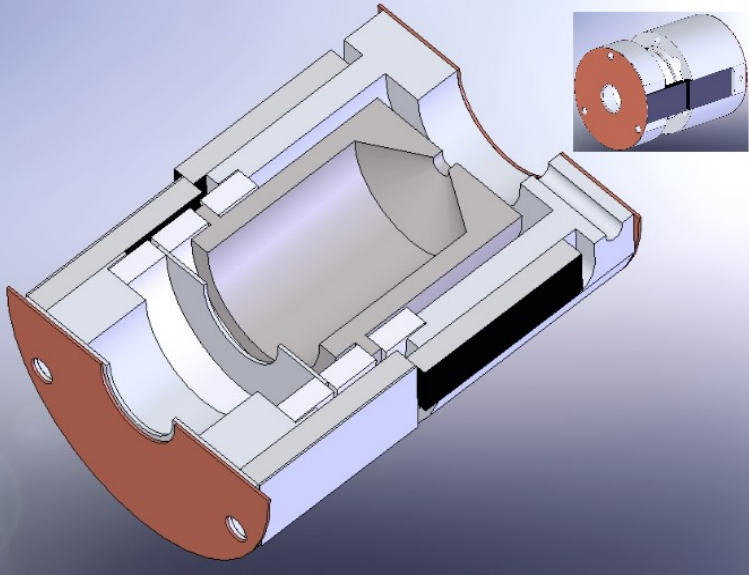

Azimuthal scan shows negative ion currents corresponding to jets.

background pressure: 2 mTorr

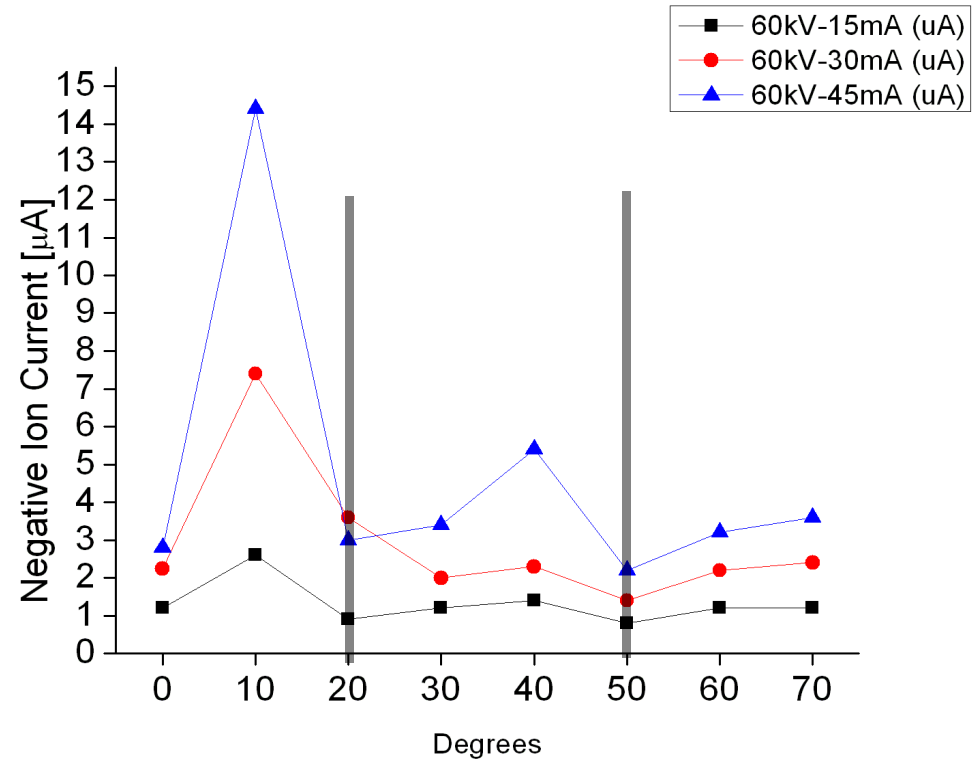
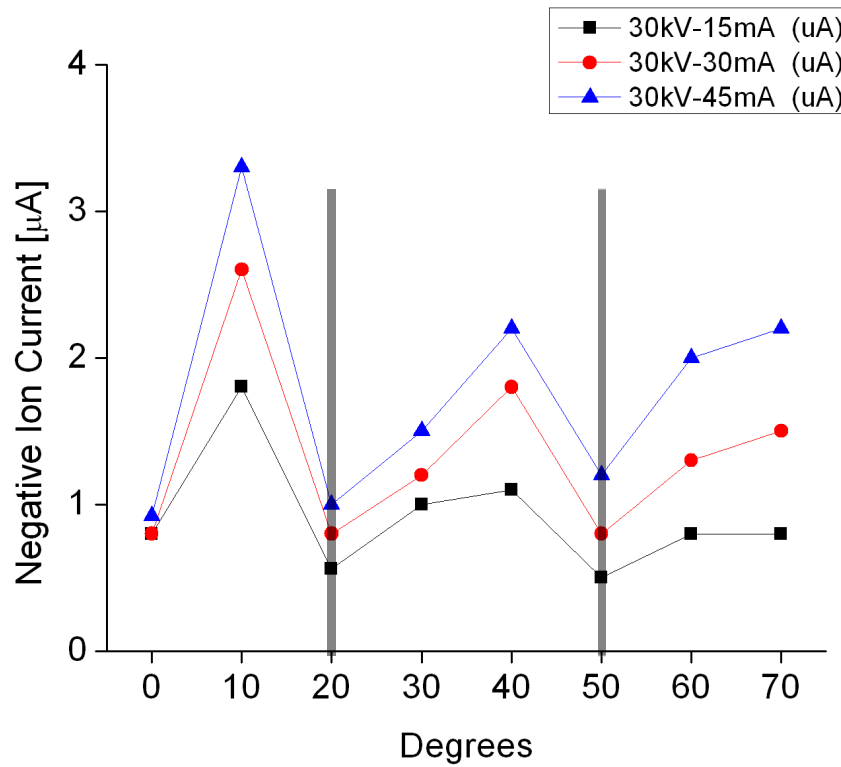

Fine azimuthal negative ion profiles show jet dynamics sensitive to cathode voltage.

background pressure: 2 mTorr

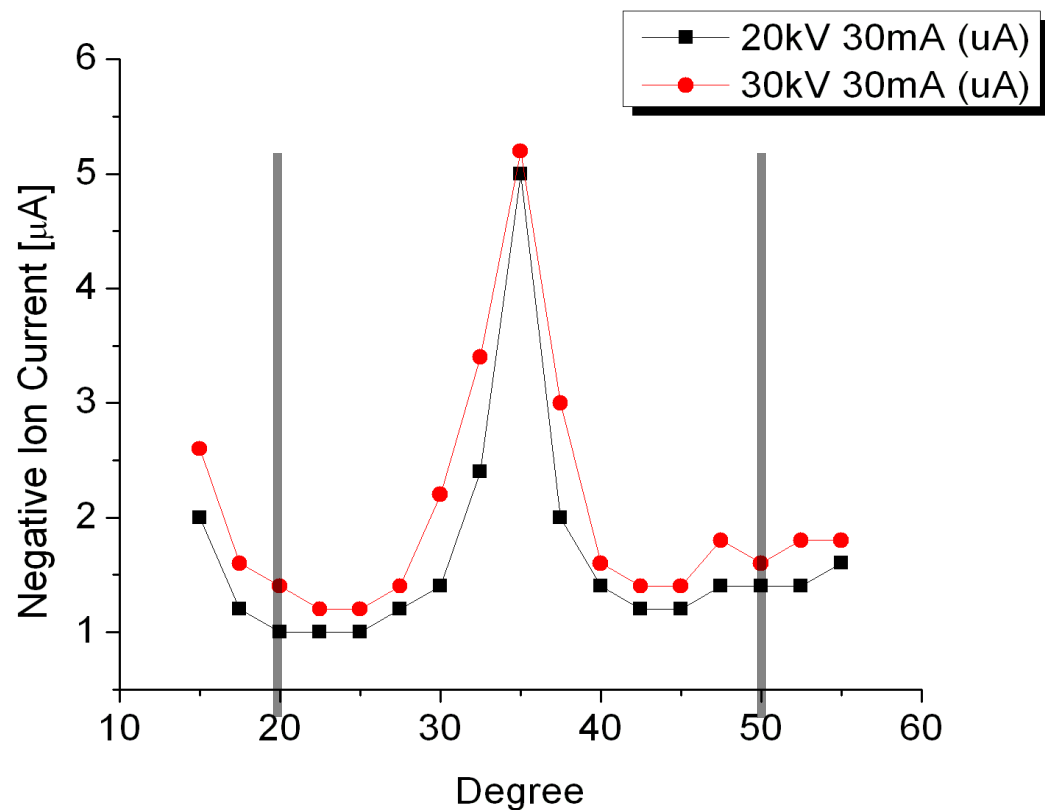
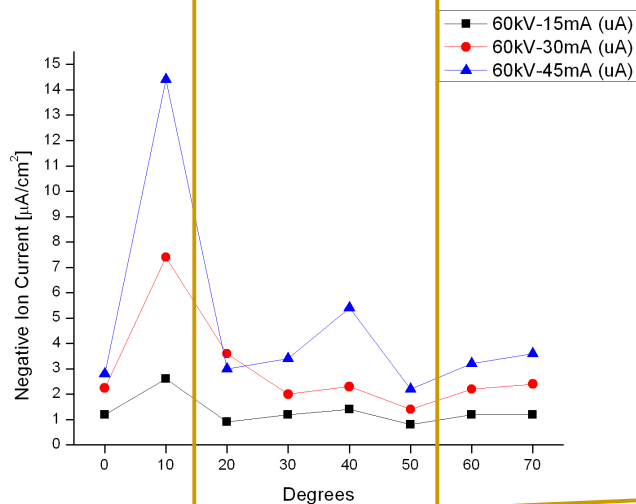
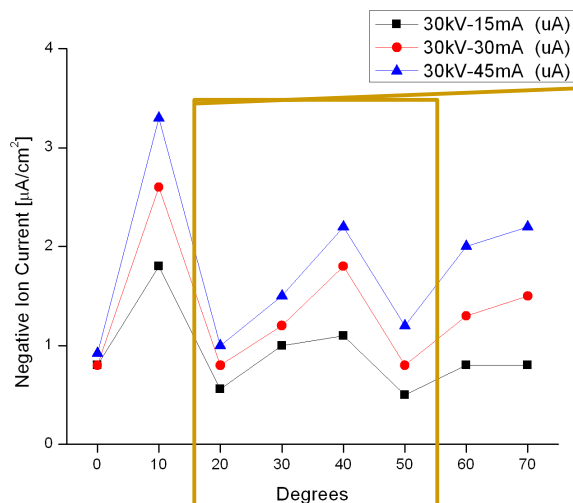

Fine azimuthal negative ion profiles show jet dynamics sensitive to cathode voltage.

background pressure: 2 mTorr

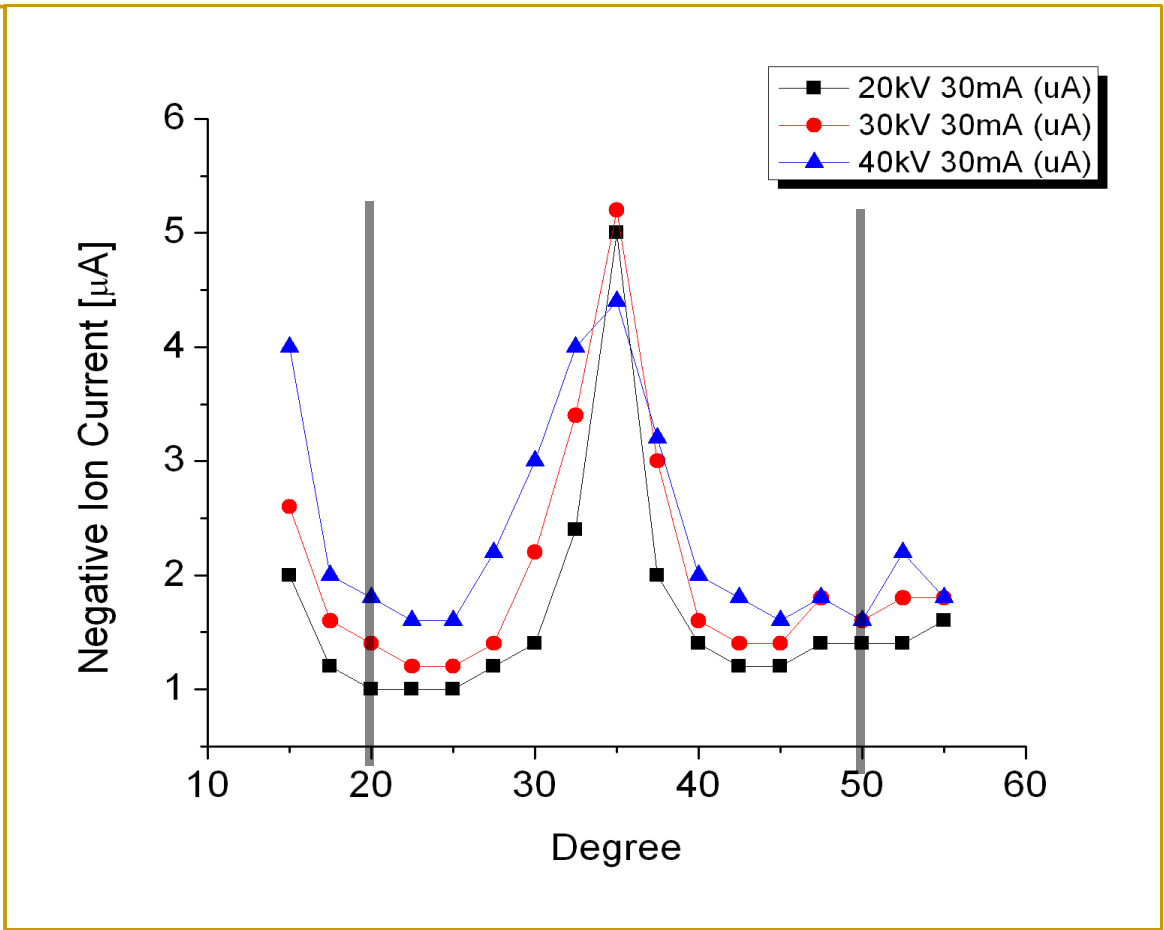
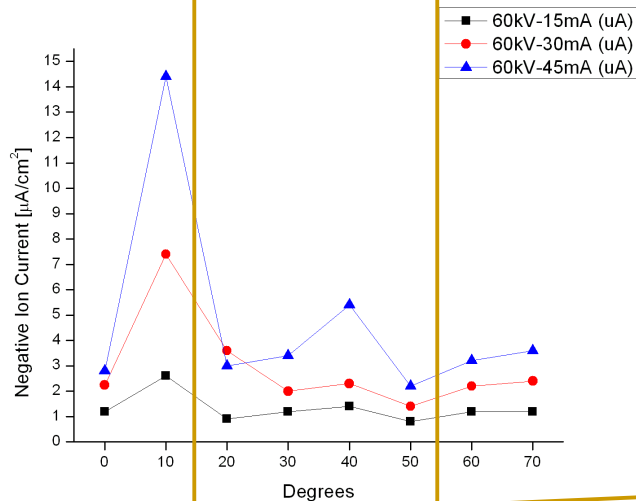
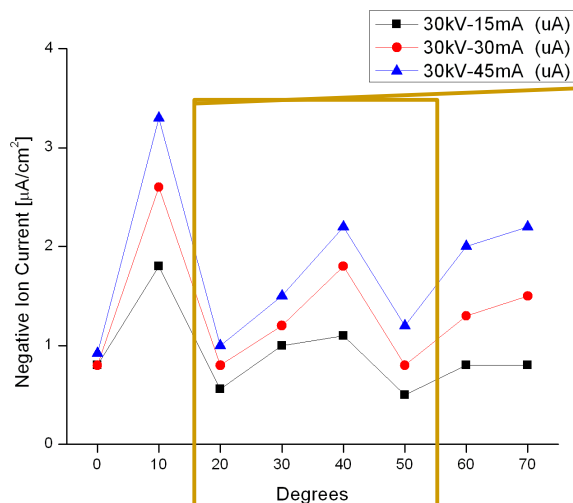

Fine azimuthal negative ion profiles show jet dynamics sensitive to cathode voltage.



background pressure: 2 mTorr

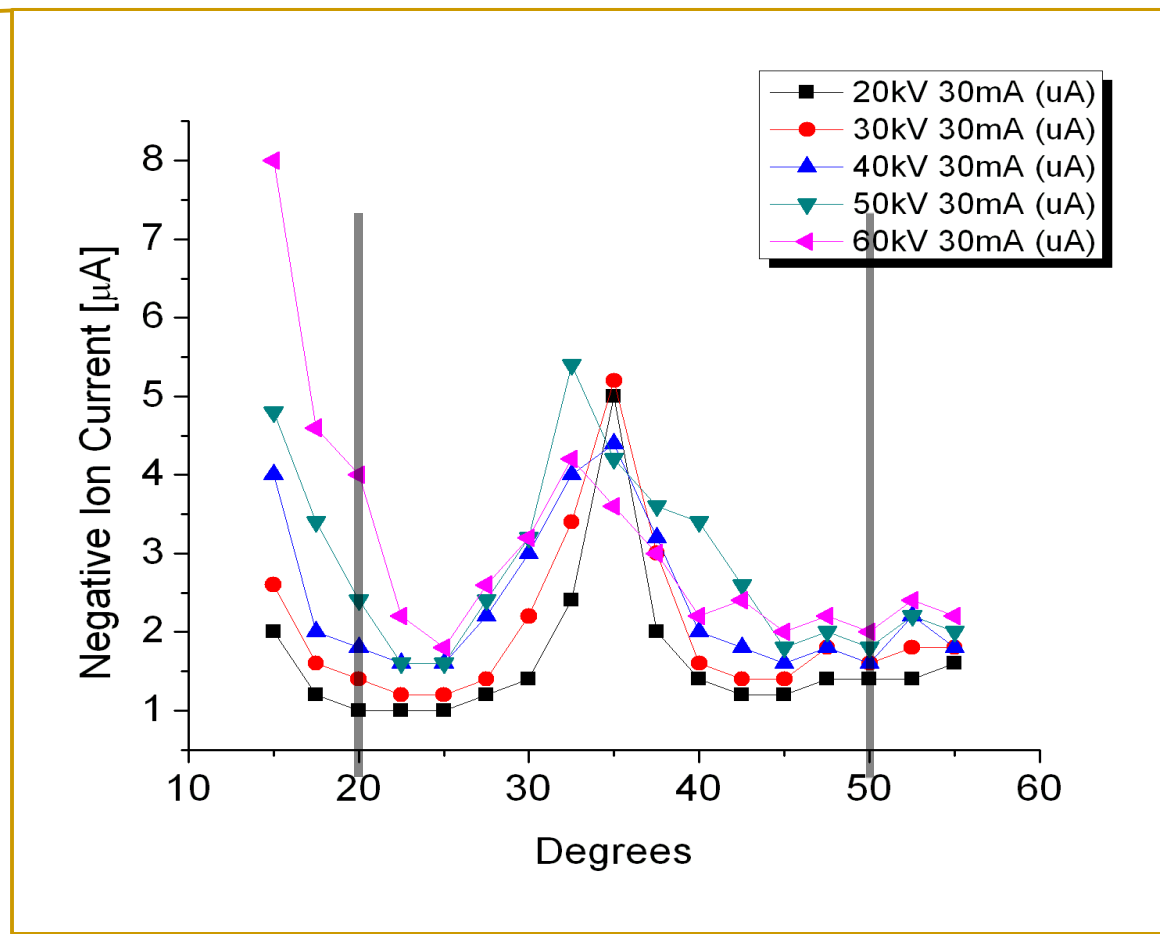
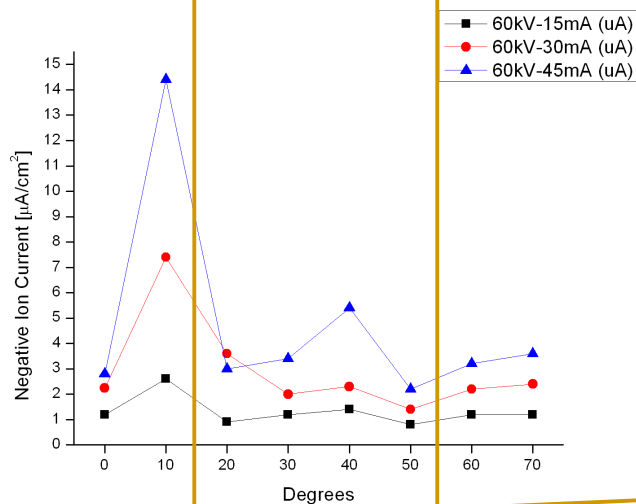
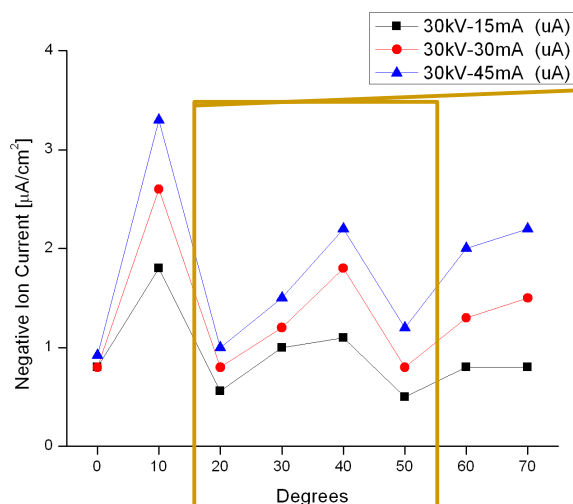

Future Work



- Continue parametric simulations of negative ion spectra on VICTER code.
- Continue parametric studies of jet dynamics via azimuthal scans.
 - Anode-Cathode geometry
 - Cathode voltage
 - Cathode current
 - Background pressure
 - Negative ion current dependence on radius
- Attempt negative ion focusing using modified cathode.

Summary



- VICTER code negative ion subroutine is producing interesting results for parametric studies.
 - Code results showing trends reflected in experimental results
 - Code under-predicting number and energy of negative ion current
- Azimuthal scan of Faraday cup showing evidence of negative ion jet structure.
 - Jet intensity and shape responds to cathode voltage and current
- Negative ions are a useful way to improve our understanding of IEC device physics.

Questions?



Voltage: 100 kV, Current: 30 mA,
2 mTorr

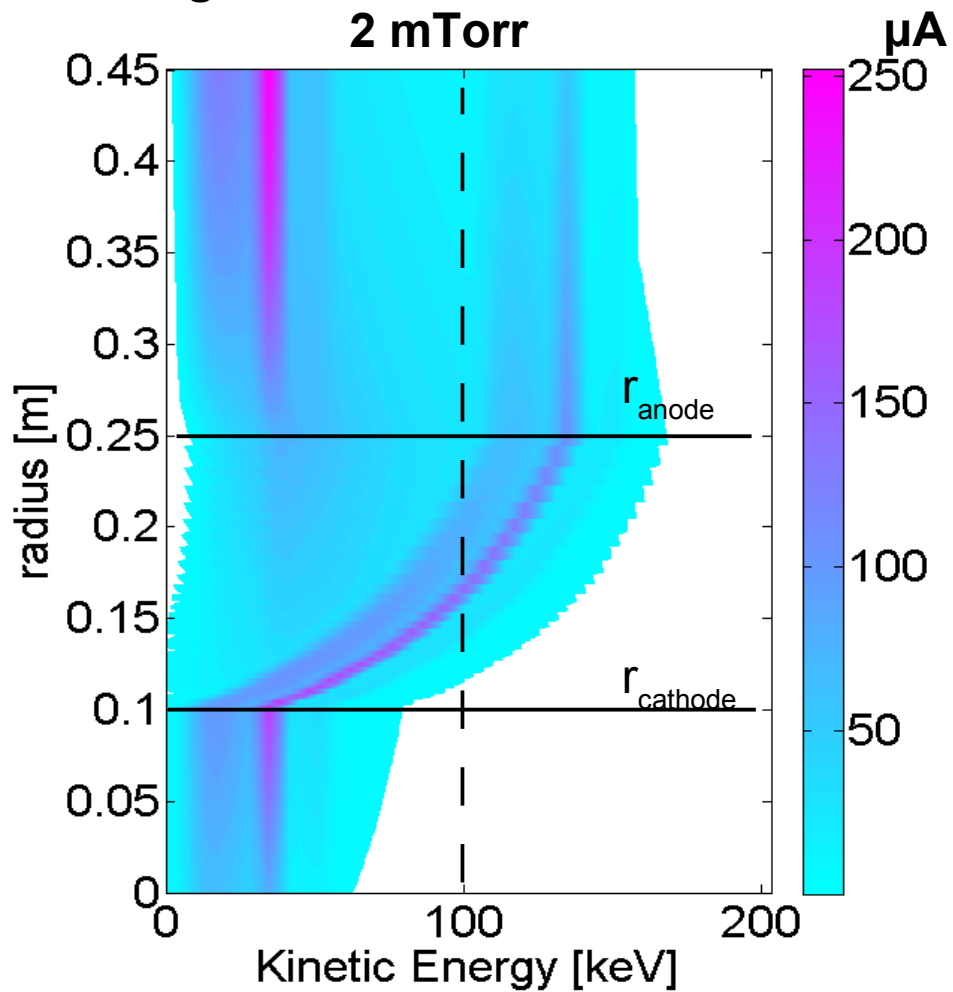

background pressure: 2 mTorr

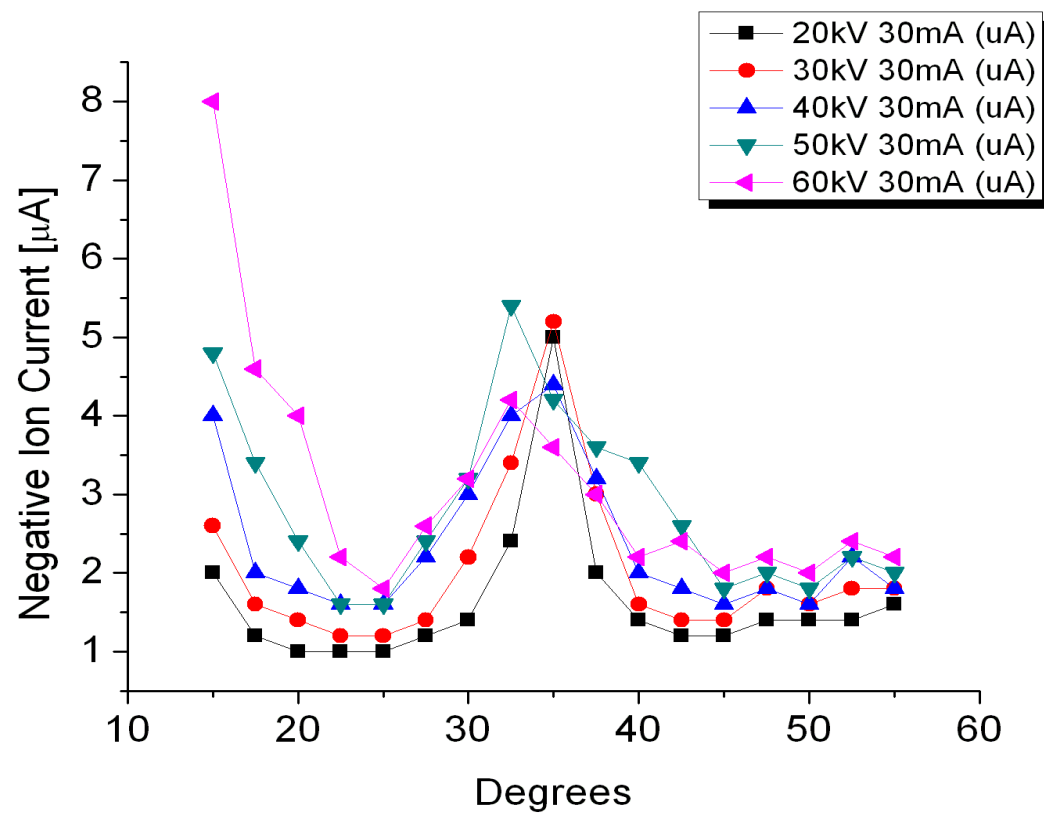

Magnetic Deflection Energy Analyzer diagram

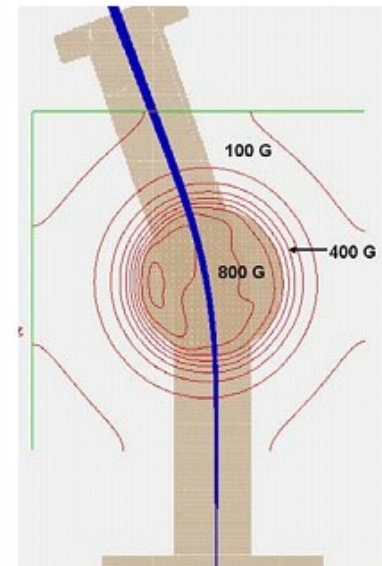
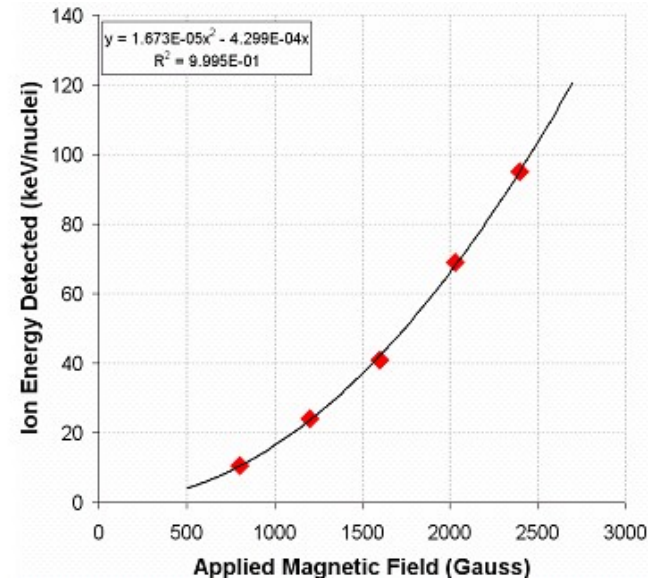
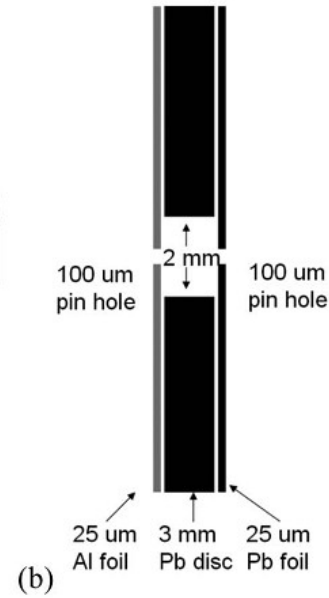
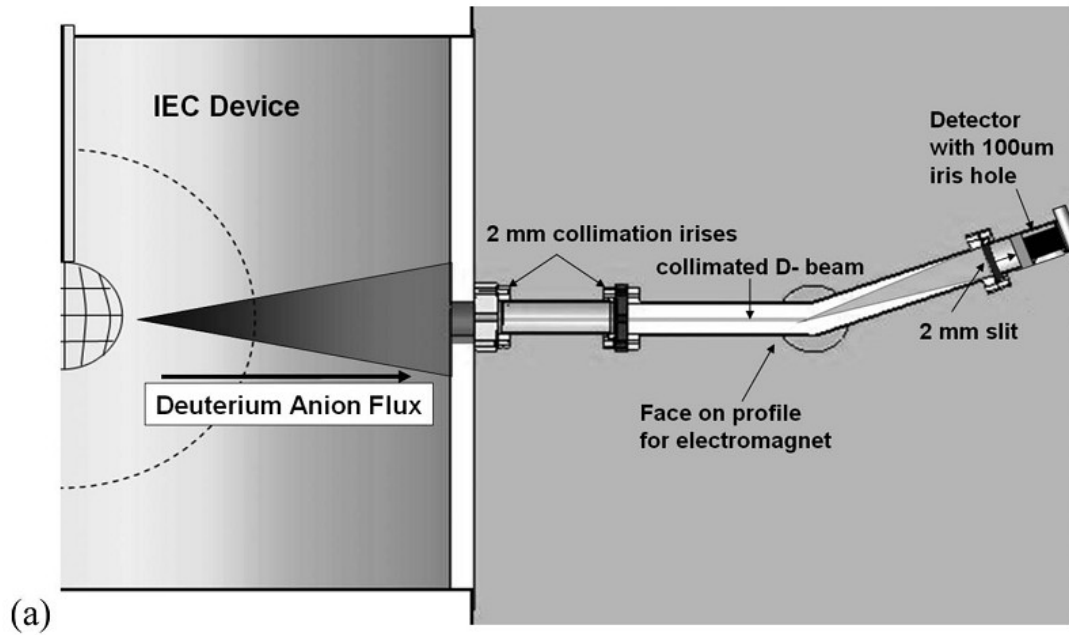

Magnetic Deflection Energy Analyzer at various cathode voltages shows spectrum hardening.

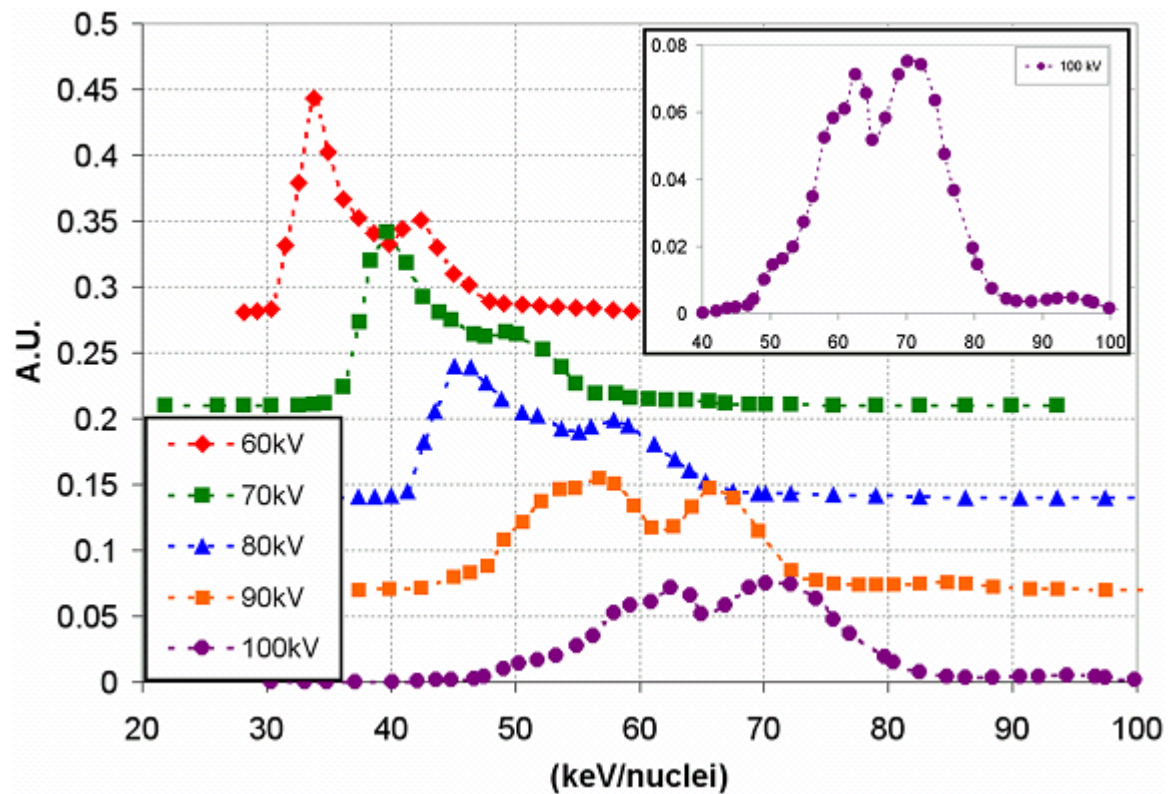

Title Goes Here



THE UNIVERSITY
of
WISCONSIN
MADISON