

REVIEW QUESTIONS

IMPORTANT NOTES

- The following questions are based on recent examination papers.
- Most of them are examples of *one* type of question that will appear on your examination paper: quantitative questions involving assessment of a given situation, selection of appropriate relations (formulas), explanations and arithmetic.
- Some questions (11, 23, 24, 44 and 46) are more qualitative. A presentation of memorised slabs of the notes is invariably an unsatisfactory answer to such questions.
- Note that *both* styles of questions, *in roughly equal number*, will appear on your exam paper.

- 1 The graph shows the speed-time curves for two racing cars, the Hawk and the Tearaway

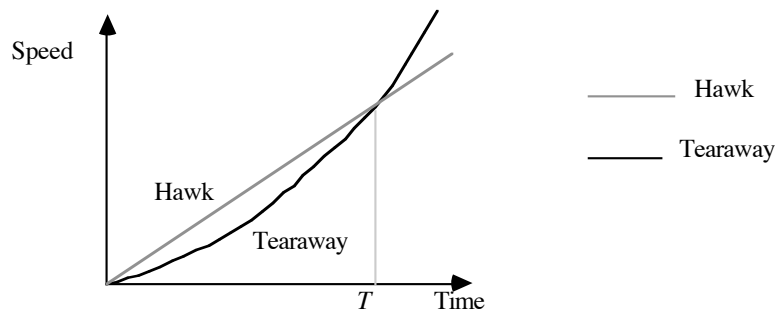

The two cars start together at time $t = 0$ and the race finishes at time $t = T$. Which car wins? Explain.

- 2 A dolphin, swimming in a straight line, is observed to uniformly increase its speed from 1.0 m.s^{-1} to 9.0 m.s^{-1} in 5.0 s . Determine, by graphical methods or otherwise,
- its acceleration, and
 - how far it travels in this interval.

- 3 A car is travelling on a straight horizontal road. It moves off from rest with a constant acceleration of 0.50 m.s^{-2} . It stops accelerating after 16 s and moves with a constant velocity for a further 14 s . It then slows down uniformly and comes to rest 40 s after leaving its starting point.
- Draw a graph of velocity against time for the 40 s . Label the axes carefully.
 - What is the acceleration of the car at $t = 35 \text{ s}$?
 - What is the total distance covered by the car in its journey?

- 4 A billiard ball of mass 0.20 kg is struck by a cue. The graph below shows the net force on the ball as a function of time.

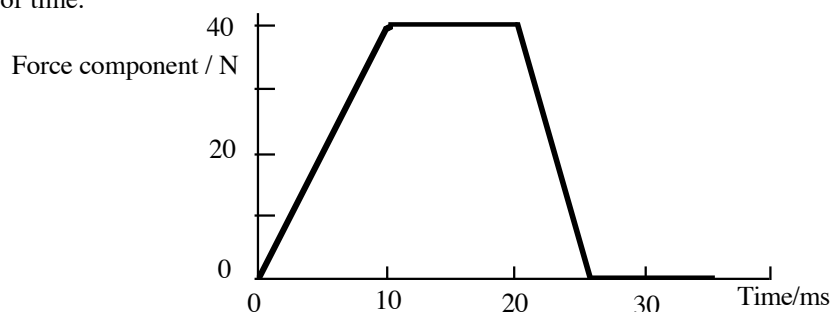

- Plot a graph of the ball's acceleration as a function of time.
- Calculate the maximum values of
 - the acceleration,
 - the velocity of the ball.

- 5 The graph below shows how the speed (v) of a car, travelling in a straight line, varies with time (t) from the instant when the driver perceives an emergency. Note the reaction time of 0.20 s before the brakes are applied and the total time interval of 2.2 s before the car stops.

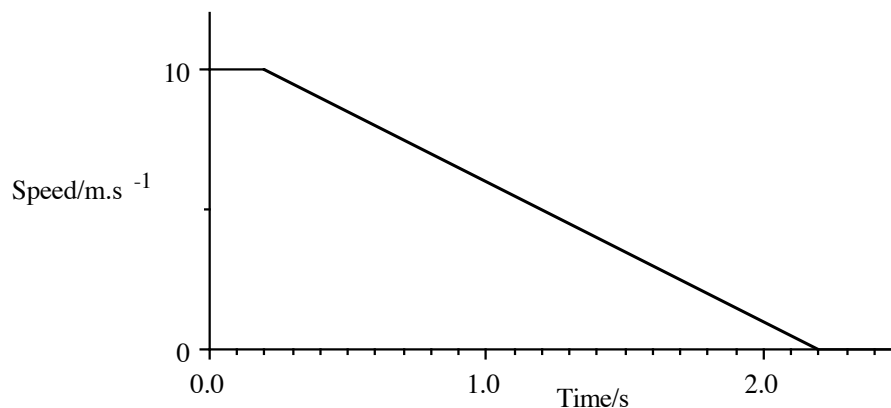

- Calculate the average acceleration from the time when the brakes are applied to the time when the car stops.
- Calculate the distance travelled by the car after the time when the driver perceives the emergency.
Consider a drunken driver whose reaction time is twice as long as that of the sober driver described above. The drunk is initially travelling twice as fast as the sober driver. Their cars are similar and the braking force is the same in both cases
- Calculate the time from the emergency until the car stops.
- Calculate the distance travelled by the car after the emergency.

6

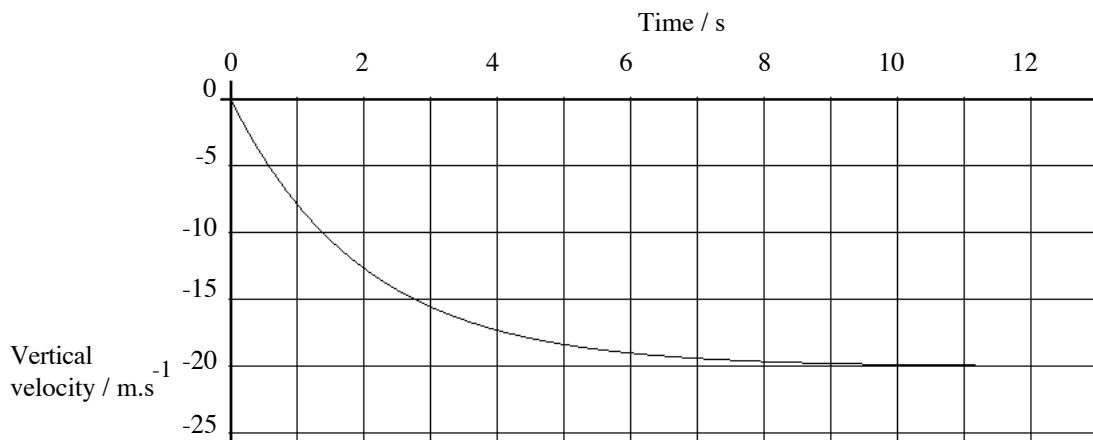

The vertical component of velocity as a function of time for a falcon diving on its prey is shown in the graph.

Contact with the prey is made at $t = 12$ s.

In this problem ignore the buoyant force of the air on the falcon.

- What is the initial vertical acceleration of the falcon?
- Initially, how far below the falcon is the prey?
- Explain the variation of velocity in terms of the forces acting on the falcon.
- What is the magnitude of the vertical component of the total force on the falcon at $t = 10$ s?

- 7 Suppose that you have been driving with a friend and have parked at the side of the road. When you come to start the car again, it won't start. In order to get it moving your friend is going to push it, while you remain behind the wheel.

The road is flat and it takes 5 s to get the car up to a velocity of 0.5 m.s^{-1} .

- If the velocity increases at a constant rate, and the car travels in a straight line, what is the magnitude of the acceleration?
 - What is the car's displacement at the end of that 5 s interval?
 - The car's mass is 1500 kg. Your friend pushes with a force of 200 N. Describe the horizontal forces acting on the car.
 - How great is the force opposing the motion?
-
- 8 The net force acting on an object of mass 0.50 kg remains fixed in direction; the magnitude of the net force changes with time as shown in the graph below. The object was at rest before this net force was applied.

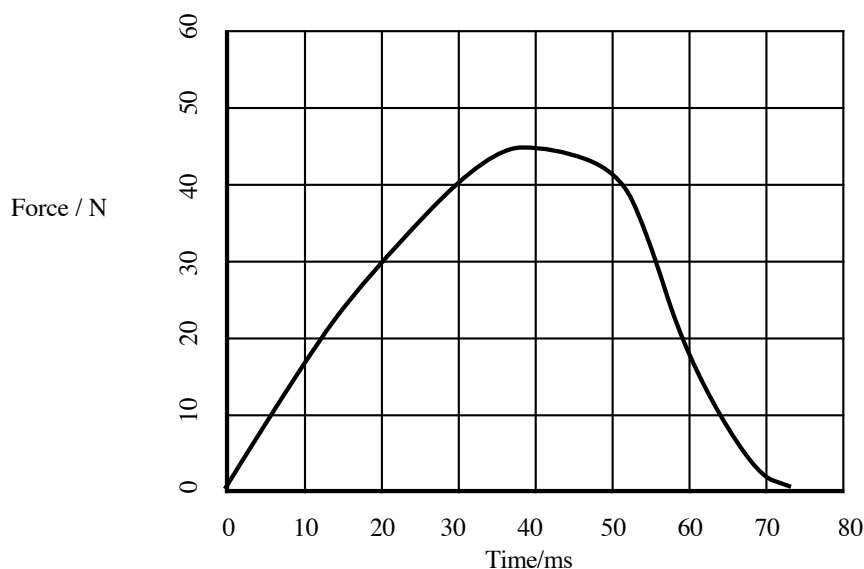

- What is the maximum value of the acceleration of the object?
 - What is the time interval between the force being applied to the object and the object attaining its maximum speed?
 - Describe how this maximum speed can be found and estimate its value.
-
- 9 Briefly explain the operation of a centrifuge for separating small solid particles from a fluid. Your explanation may be given in terms of *either* the laboratory frame *or* the rotating frame. State which frame you are considering, describe the path of a particle in that frame and list the forces acting on the particle.

10

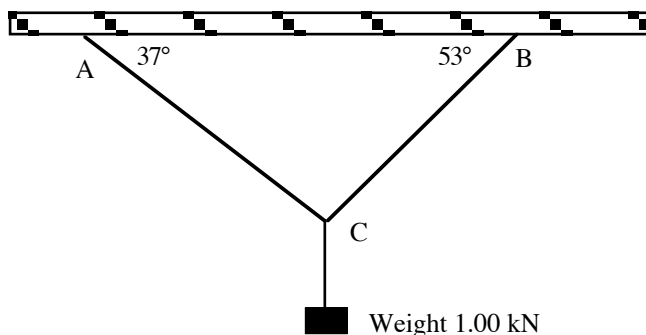

An object weighing 1.00 kN is suspended using three wires as shown in the figure. Calculate the forces exerted by the wires on the supports at A and B. Briefly explain your reasoning.

- 11** There are four types of fundamental force.
- List them in increasing order of strength.
 - Which of them are attractive, which are repulsive and which may be either?
 - For each of the four types of force, give an example of a situation in which that type of force is dominant.

- 12** Suppose that you have decided to construct a mobile using discs, wires and strings. You would like it to look like this:

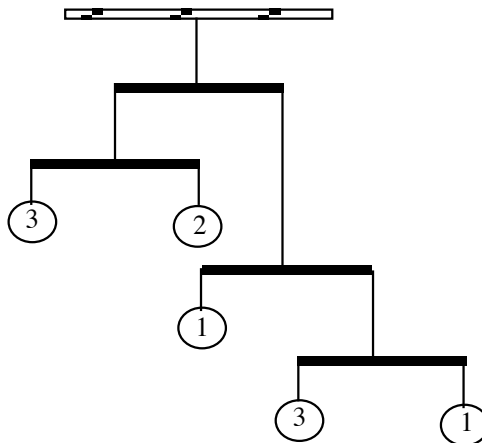

The discs are attached to the ends of the wire arms as shown. The numbers in the discs are their masses in grams. Each arm is 10 centimetres long.

If the supporting strings are attached at the mid-points of the arms, the mobile will not hang like this - with its arms horizontal.

Can you shift the supporting strings from the mid-points of the arms so that the arms are horizontal? Where are the new points of attachment? (Assume that the masses of the strings and the wire arms are negligible.)

What is the total downward force on the top string?

In reality, the masses of the arms may not be insignificant. Indicate how this will affect the positions of the new points of attachment.

- 13** DATA: Density of air = 1 kg.m^{-3} .
 Density of water = $1 \times 10^3 \text{ kg.m}^{-3}$.
- Suppose that you are standing on the bathroom scales weighing yourself. Estimate the buoyant force on you. What fraction of your weight is that? Do you need to take it into account when you weigh yourself?
 - Here is a way of measuring the density of alcohol. Attach a solid metal object to a spring balance by a cotton thread.

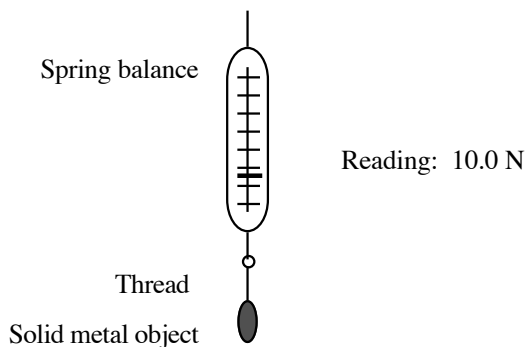

Suppose that the spring balance registers a force of 10.0 N. Now immerse the object in water.

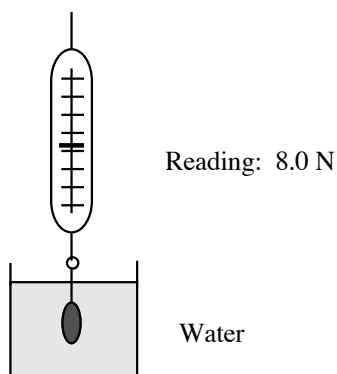

Suppose that the new reading is 8.0 N.

Finally immerse the object in alcohol. If this last reading is 8.4 N, what is the density of alcohol?

- 14** A wheel nut on a motor vehicle has been put on in a garage with an automatic nut tightening device so that it needs a torque of $2.50 \times 10^2 \text{ N}\cdot\text{m}$ to loosen it again. A driver wishing to change the wheel can pull with a force of no more than $4.00 \times 10^2 \text{ N}$. What is the minimum length of spanner required?

15

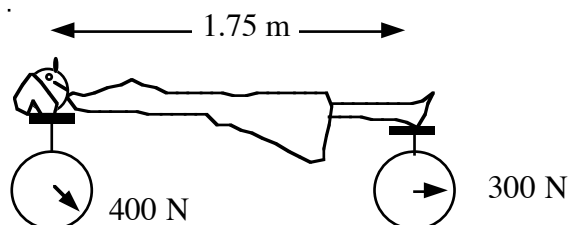

The diagram illustrates an experiment to locate the centre of gravity of a woman lying on her back, supported by two scales.

At equilibrium the scales have the readings shown.

What is her weight?

How far from her feet is her centre of gravity?

16

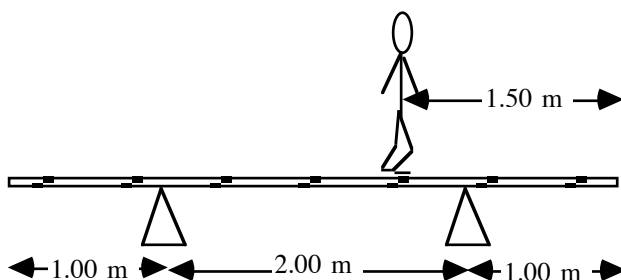

A uniform plank, 4.0 m long, weight 200 N, is supported by two trestles as shown on the figure. A man, weight 800 N, stands 1.5 m from one end. What is the force on each trestle?

Suppose the man walks towards one end. Where will he be standing when the plank begins to tip?

- 17** A light rod 4.0 m long is pivoted 1.0 m from the end. A 3.0 kg body is suspended from the end of the rod nearest the pivot.
- What mass would have to be suspended from the other end to balance the rod?
 - The rod is now replaced by a uniform steel bar of mass 2.0 kg. What mass is now required to balance the rod?

18

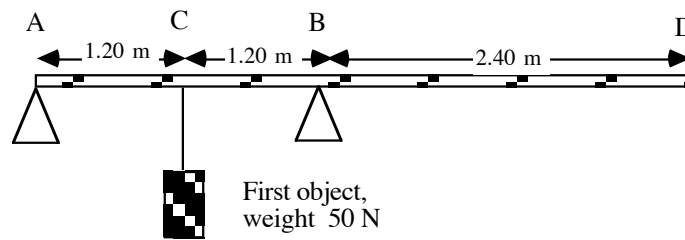

- a) A uniform plank of length 4.80 m and weight 0.200 kN is supported at two points A and B as shown in the figure. An object of weight 50 N is suspended at C. Calculate the forces that the supports exert on the plank at A and B.
- b) A second object is suspended at the end D. What is the weight of the object given that the plank is just about to tilt?

19 Traction can be applied to a leg as shown.

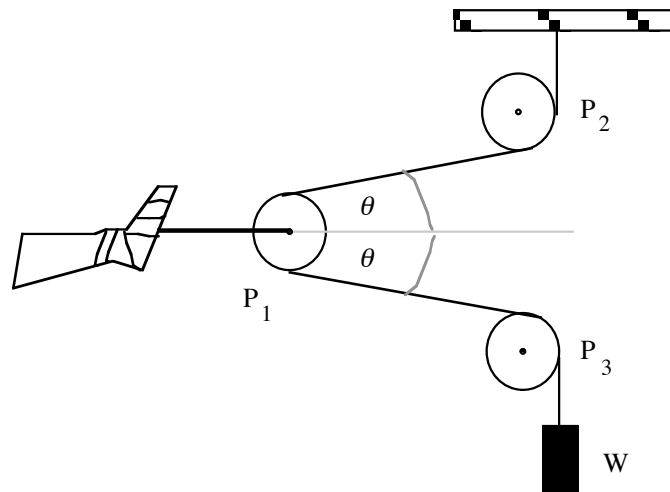

W is a body whose weight is 100 N held on a light flexible cord which passes around low friction pulleys P_1 , P_2 , P_3 . P_1 is moveable and is attached to the foot. P_2 , P_3 are fixed and are attached to a rigid frame (not shown).

The magnitude of the force exerted by the contraction on the foot is 50 N.

- a) Calculate the angle θ when the force of 50 N is applied.
- b) What other force (not indicated in the diagram) would be required to prevent the patient being pulled out of bed?

20 A horizontal square trapdoor of mass 10 kg pivots about one edge. A force of at least 75 N applied at the opposite edge, is required to make the trapdoor swing upwards. Determine the location of the centre of gravity of the trapdoor.

- 21 When the arm is raised to a horizontal position, the forces on the upper arm bone are as shown in the figure.

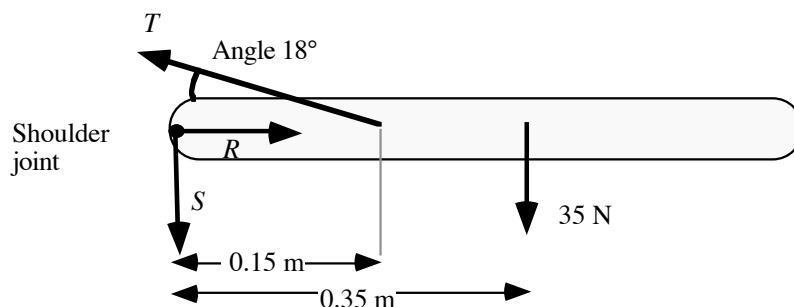

Calculate

- the force T exerted by the muscle,
 - the two components R and S of the force at the shoulder joint.
-
- 22 A spring "balance" is calibrated to indicate the mass of an object which is suspended from the balance. A waterproof object "weighed" in air has a mass of 0.210 kg. When the same object (but not the balance) is suspended in sea water, the reading obtained from the balance is 0.150 kg. Given that the density of sea water is $1.10 \times 10^3 \text{ kg.m}^{-3}$, calculate the volume of the object.
-
- 23 Give a brief explanation of the diffusion process. What are the main properties of this process? What restrictions do these properties place on the types of living organisms possible?
-
- 24 The following forces may be experienced by objects in fluids because of collisions with the fluid molecules:
- buoyant force,
 - drag force,
 - forces that cause diffusion.
- Distinguish between them.
-
- 25 A helium balloon is released from ground level.
- Draw a labelled diagram showing all the forces acting on the balloon. Explain the origin of the forces.
 - Sketch a graph of the vertical velocity of the balloon, explaining any important features of the graph.
-
- 26 Consider a small particle of density d and volume V falling in a fluid of density d_1 . ($d_1 < d$).
- What forces act on the particle?
 - What is the value of the buoyant force on the particle?
 - If the body has been released from rest in the fluid, sketch the velocity-time graph for the subsequent motion.
-
- 27 A kite of mass 1.5 kg flying at an altitude of 102 m in a steady horizontal wind produces a pull on its light string of 208 N when the string is at an angle of 60° to the horizontal. What are the magnitudes of the lift and drag forces?
-

28 The graph shows the potential energy of a system of two ions as a function of their interionic separation.

Note that: $1 \text{ aJ} = 1 \times 10^{-18} \text{ J}$ and
 $1 \text{ nm} = 1 \times 10^{-9} \text{ m}$.

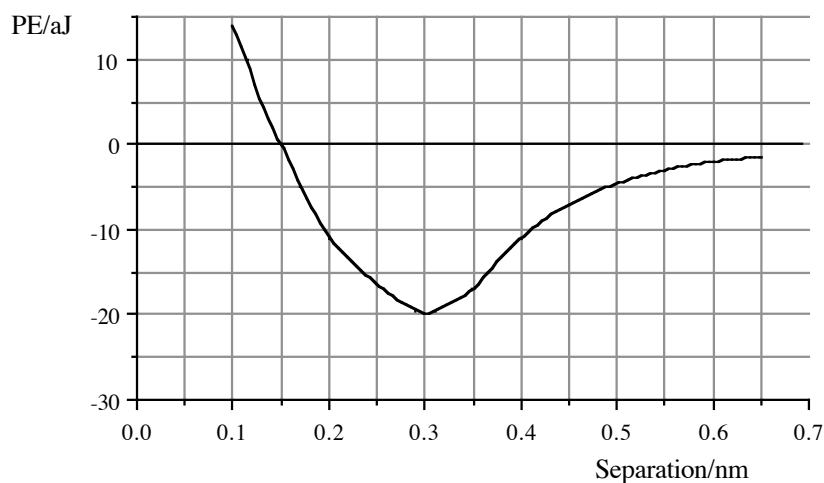

The system of the two ions has a total mechanical energy of $-0.5 \times 10^{-17} \text{ J}$.

- What is the range of possible values for the distance between the two ions?
- At what separation do the ions have minimum kinetic energy?
- What is the maximum possible kinetic energy of the ions?
- What energy is required to break apart this ionic molecule?

29 A glider is connected by a tow-rope 500 m long to a moving truck. The glider is at a height of 400 m and is flying horizontally with a steady speed of 100 km.h^{-1} . The mass of the glider is 200 kg. The tension in the rope is 1500 N.

- Draw a diagram showing all the forces acting on the glider.
- Find the magnitudes of all these forces (ignoring any buoyant force).

30 A glider is travelling at a constant velocity at an angle of 10° below the horizontal.

- Show clearly on a diagram the directions of the forces acting on the glider.
- What is the ratio of the magnitude of the lift force to that of the drag force?

31

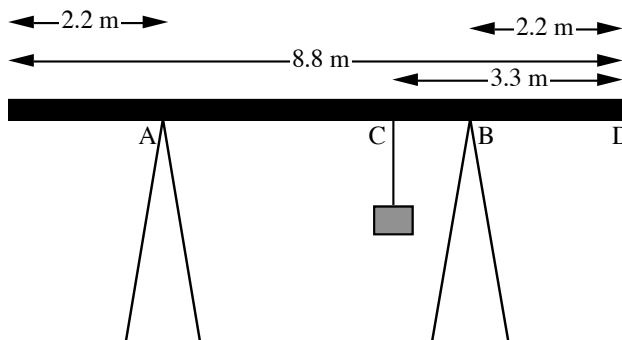

A uniform plank of length 8.8 m and weight 50 N is supported, as shown in the figure, at two points A and B. A and B are both 2.2 m from the ends of the plank. An object of weight 130 N is suspended at C, which is 3.3 m from the end D.

- Calculate the forces that the supports at A and B exert on the plank.
- A second object is suspended at the end D. What is the weight of the object if the plank is just about to tilt?

- 32 A flea leaps vertically in the air. The first portion of a height vs time graph of its leap (obtained by high speed motion photography) is shown below.

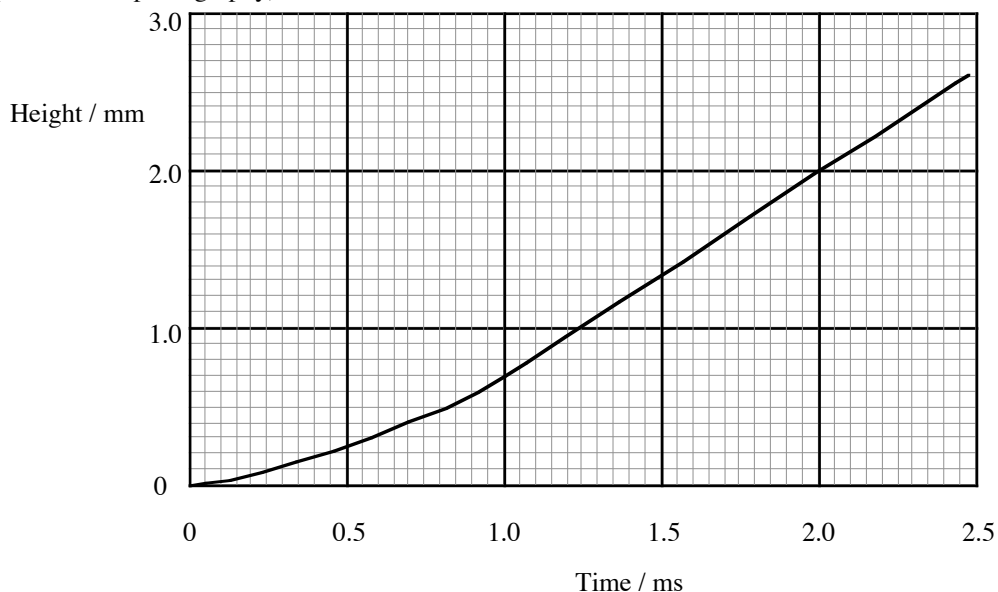

- a) Sketch the corresponding graph of the vertical velocity vs time.
 Note that great accuracy is **not** required but you should indicate the magnitudes of the velocity and the time on the appropriate axes.
 Show clearly on your graph the time when the flea's feet leave the ground, i.e. when the pushing stage is completed.
 Estimate the average acceleration during the pushing stage.
- b) If air resistance was negligible so that total mechanical energy was conserved, how high do you think the flea jumped?

- 33 An object thrown vertically upwards through the air experiences a drag force.
 Show that it will always take longer for the object to come down than to go up.

- 34 An elevator lifts coal from the bottom of a shaft which is 200 m deep to the top of a stack which is 15 m above ground level. The mass of the loaded elevator is 1.20×10^3 kg.
- a) Taking the zero of potential energy at ground level, calculate the potential energy of the loaded elevator when it is at
- the top of the stack,
 - ground level,
 - the bottom of the shaft.
- b) If the zero for potential energy is taken at the bottom of the shaft, what is the change in the values calculated in (a)?
- c) Suppose that the elevator cable breaks when the elevator is 40 m below ground level. Calculate the speed of the elevator just before it hits the bottom. Neglect air resistance.

- 35 The strong nuclear force as a function of distance between a neutron and proton is shown.
 (1 fm = 1×10^{-15} m.)

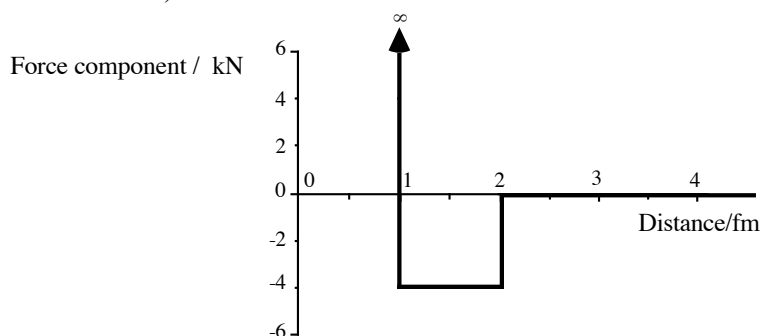

A neutron approaches a stationary proton from a great distance with initial kinetic energy 2.0×10^{-12} J.

- a) What is the closest distance of approach of the two particles?
 b) What is the kinetic energy of the neutron when $d = 1.5$ fm?

- 36** An object falls to the ground from a height of 10 m.
- Calculate its speed when it strikes the ground.
 - Calculate the height it will rise to if it loses 20% of its energy during contact with the ground.

- 37** The graph below shows the magnitude of the force exerted by a nucleus on a neutron at various distances from the centre of the nucleus. The force is conservative and along the line joining the centre of the nucleus to the neutron.

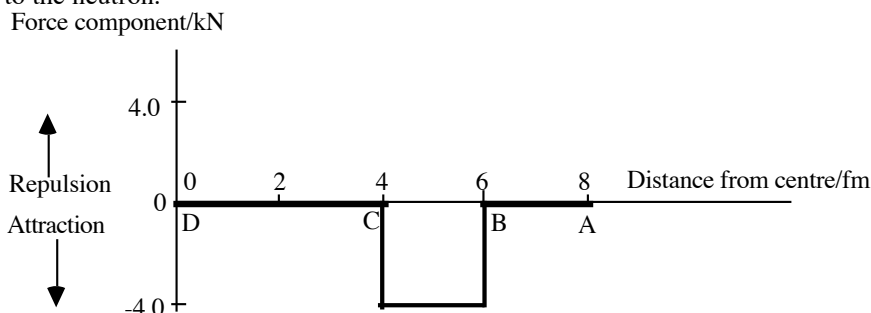

- Assume that when the neutron is at point A outside the nucleus, the neutron-nucleus system has zero potential energy.
Find the potential energies of the system when the neutron is at the points B, C and D.
Hence draw the potential energy diagram for the system.
- What is the minimum kinetic energy that a neutron at the centre of the nucleus must have to escape from this nucleus (i.e. to reach point A)?

- 38** A 0.050 kg stone is wedged in the tread of a car tyre 0.25 m from the axle. A radial force of 180 N would free the stone.
The stone flies off when it is at the top of the wheel. How fast is the car travelling?
Sketch the subsequent path of the stone.

- 39** Goliath's skull will fracture if an energy of 20 J is imparted to it in a short period and over a small area. David has a stone of mass 0.10 kg and a sling of length 1.0 m. He whirls the stone at the end of the sling and then releases the stone. The stone hits Goliath and comes to rest while in contact with his forehead.
Since all motion here is presumed to be horizontal, the effects of gravity should be ignored throughout this question.
- What must be the speed of the stone to fracture Goliath's skull?
 - What is the angular velocity of the stone at the time David releases it?
 - What tension must the thong of the sling be able to withstand?

- 40** As a result of the earth's rotation, a point on the equator is moving about the centre of the earth at about 500 m.s^{-1} . The radius of the earth is about $6 \times 10^6 \text{ m}$.
- Calculate approximately the centripetal acceleration of an object at the equator.

A person, mass 70 kg, is standing at the equator.
 - What is the magnitude of the centripetal force on the person?
 - What provides that force?

- 41** A runner on a circular track completes one lap of 400 m in 50 s at a steady speed of 8 m.s^{-1} .
- Calculate the angular velocity of the runner.
 - Calculate the magnitude of the acceleration of the runner.
 - Describe the nature of the force responsible for this centripetal acceleration.

- 42** An athlete with arm outstretched hurls a discus at an initial speed of 8 m.s^{-1} . The mass of the discus is about 8 kg. The length of the athlete's arm is about 0.5 m and its mass can be ignored in comparison with that of the discus.
Calculate the angular velocity of the athlete's arm at the instant when the discus is released.
What tension exists in the arm at the time the discus is released?

- 43 A gramophone record rotates at $33\frac{1}{3}$ revolutions per minute.
- What are the values of the following quantities 12 cm from the centre of the record?
 - the period of rotation in seconds,
 - the angular velocity,
 - the tangential velocity.
 - Which of these will have different values 5 cm from the centre of the record?
 - An object, mass 5 g, is placed on the rotating record 12 cm from the centre. Calculate the centripetal force required to hold it there.

- 44 The figure below shows an example of an antisocial method of disposing of waste material.

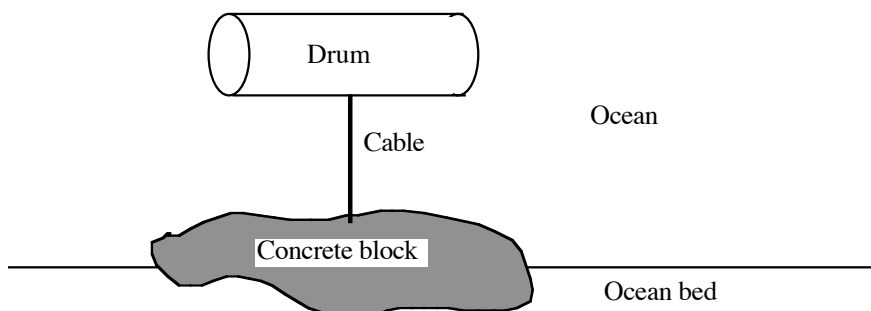

A drum is anchored by means of a cable to a very heavy concrete block sitting on the ocean bed. The total weight of the drum and its contents is about half the buoyant force on the drum.

Suppose the cable were to break. Sketch a graph of the upward velocity of the drum as a function of time,

- while the drum is completely surrounded by water and
- after the drum reaches the surface.

In each case give a *brief* qualitative explanation of your graph in terms of the forces acting on the drum.

- 45 In a tractor most of the large amplitude vibrations occur in a frequency range from 4 Hz to 8 Hz. The driver sits on a spring-mounted seat which is depressed by 10 mm.
- What is the natural frequency of the driver on the seat?
 - Explain why this arrangement would not be comfortable while the tractor is operating.
 - What would you change to provide a smoother ride? Explain your answer.

- 46 Explain how the mass of a fly trapped in a spider's web could be estimated by studying the oscillations of the web and fly.

- 47 One cycle of the velocity-time curve for a particle is shown.

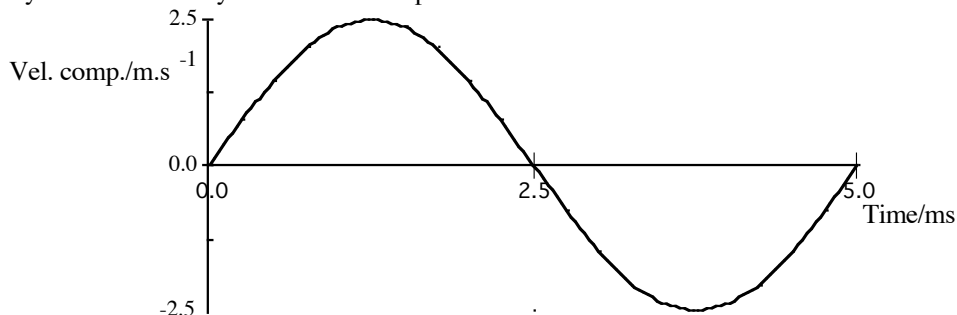

- Calculate the vibration frequency of the particle.
- For what value(s) of the time t is the particle at the equilibrium position?
- Calculate the maximum value of the magnitude of the particle's acceleration.

-
- 48** At the end of Puccini's opera, the distraught Tosca jumps from the battlements of the Castle St Angelo. In one production with an unpopular soprano, the stage hands replaced the heap of mattresses on which she was to fall by a trampoline. Assume that Tosca weighed 1000 N.
- If she fell through a height of 1.8 m what was the change in her gravitational potential energy?
 - Describe, in terms of energy transfer, her subsequent motion until she finally comes to rest on the trampoline.
 - Explain whether this motion can be considered as an example of simple harmonic motion.
 - If the trampoline had a spring constant of $1 \times 10^4 \text{ N.m}^{-1}$ how far did Tosca deform the trampoline when she was finally at rest on it?
-
- 49** Show that the surface area of similarly shaped bodies of the same density scales as the $\frac{2}{3}$ power of the mass.
Hence estimate the ratio of the surface areas of egg-shell for a 75 g egg and a 50 g egg.
-
- 50 a)** A fish has a mass of 200 kg. Estimate the mass of a larger fish whose length is 1.5 times that of the first.
- b)** A fishing line 1 mm in diameter is sufficiently strong to carry the weight of the 200 kg fish. Estimate the diameter of line required to carry the weight of the larger fish.
- c)** Why may your arguments in (a) and (b) not be exact?
-
- 51** Suppose that the acceleration of a portion of a wing is given by
- $$a = -\omega^2 x_0 \sin(\omega t)$$
- where x_0 = the maximum displacement;
 ω = the angular frequency of flapping;
and t = time.
- Write down an expression for the maximum acceleration of such a portion.
 - If the maximum force exerted by a bird's muscles is mainly associated with accelerating and decelerating the wing mass, show that this force varies as $\omega^2 L^4$, where L is the scale factor
 - Hence or otherwise show, using the observed fact that muscular force varies as the cross-sectional area of muscle, that the frequency with which birds flap their wings varies as L^{-1} .
-
- 52** Consider a skydiver who jumps from a stationary helicopter. After reaching terminal velocity the diver opens her parachute.
- In terms of the forces acting on the skydiver, explain the changes in her speed from the time she jumps from the helicopter until she opens her parachute.
 - What is the direction of the total force on the skydiver-parachute system immediately after she opens her parachute?
 - Sketch a graph showing the skydiver's speed as a function of time (from the time of jumping until just before reaching the ground).
-
- 53** A mother whale and its calf are being pursued by a whaling vessel.
- Use scaling arguments to show that the mother whale can remain submerged longer than the calf.
 - Also use scaling arguments to show that the calf can keep pace with its mother. Note that the drag force on a whale swimming underwater is proportional to the product of the surface area and the square of the speed of the whale.
-
- 54** During a spaceflight the mass of an astronaut cannot be monitored by conventional weighing techniques.
- Why?
An oscillating system could be used to monitor her mass.
 - State what quantity would be measured in this system and show how her mass is obtained from this measurement.
-

- 55 A man is in the process of putting a canoe on his shoulders (so he can carry it from his car to the river).

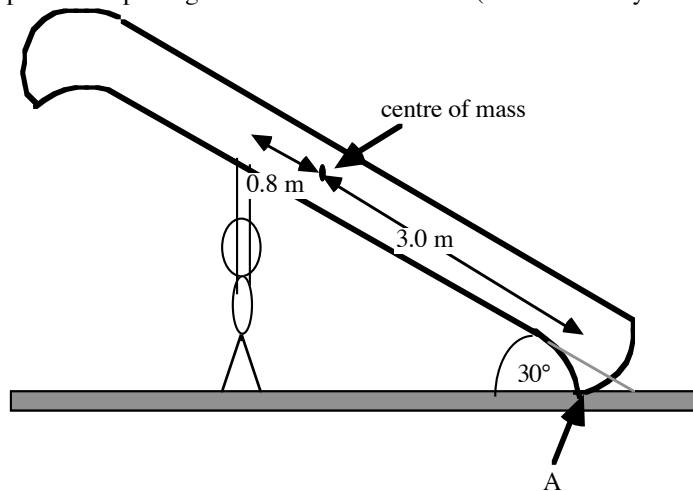

The canoe is 6.0 m long and has a weight of 425 N. Its centre of gravity is at its midpoint.

- Draw a diagram showing all the forces acting on the canoe.
- Calculate the magnitude of the contact force the man is applying to the canoe when he is pushing vertically upwards at a distance (measured along the canoe) of 0.80 m from the centre of gravity.
A friend tries to help by lifting at the end of the canoe (point A).
- Explain why this action does not reduce the force exerted by the man.

- 56 A solid brass cylinder 0.20 m high weighs 20 N.

- What is the weight of a brass cylinder of similar shape (same length to diameter ratio) with a height of 1.0 m?

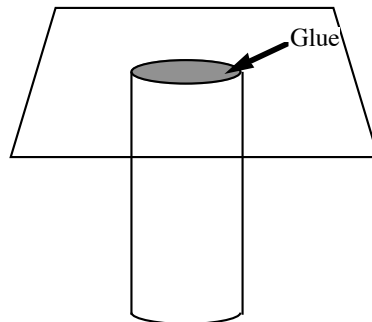

As shown in the diagram, the small cylinder is glued to the underside of a horizontal board. The force needed to break the glue is proportional to the area of contact. For the smaller cylinder on this surface this force is 125 N; if a force greater than this is applied the glue will break.

- Can the same glue hold the larger cylinder to the horizontal surface? Explain your answer.